

USER MANUAL

Turbo-ICT and BCM-RF-E

Turbo-ICT & Beam Charge Monitor RF Electronics

Rev. 4.0



www.bergoz.com

bergoz[™]
INSTRUMENTATION

More than 40 years of experience recognized in the world of particle accelerators

Record of updates

Version	Date	Updates performed
0.0	12/2012	First release
0.1	01/2013	Connectors pins allocation: corrected & updated – Summary: cleaning – Sensitivity: small change
0.2	03/2013	DB9 Remote control section removed – Architecture: DB9 remote control removed - Pin allocations table updated – Summary updated
0.3	07/2013	USB update.
1.0	02/2014	SENSITIVITY: Qcal and Ucal added, log10() instead of exp(). GUI section added, FIRMWARE section added. CALIBRATION section added. ARCHITECTURE: DB9, 6ADC.TRG.OUT added.
1.1	12/2014	General improvements and corrections
2.0	11/2016	User Manual upgrade
2.1	01/2017	Cosmetics
2.2	05/2017	Format and text corrections Improved electrical specifications of input and output signals
2.3	10/2017	Additional information regarding the data send by the BCM-RF via USB.
2.4	11/2017	Corrected a typo in the USB data format description. Added comments to the input and output signals description. Corrections in the specifications
3.0	03/2018	Review of the full manual. Obsoletes all previous versions
3.1	12/2019	Modification of the cover page and creation of the distributors' page
4.0	07/2024	Manual template update

DISTRIBUTORS

U.S.A.

GMW Associates

GMW Associates
www.gmw.com
sales@gmw.com

Japan

HR HAYASHI-REPIC

Hayashi-Repic Co., Ltd.
www.h-repic.co.jp
sales@h-repic.co.jp

India

GEEBEE
INTERNATIONAL

GEEBEE International
www.geebinternational.com
info@geebinternational.com

China

CONVe-YI 北京科维泰信

Beijing Conveyi Limited
www.conveyi.com
sales@conveyi.com

South Korea

SEYOUNG

Seyoung Co., Ltd
www.seyoungsys.com
apark@seyoungsys.com

TABLE OF CONTENTS

INITIAL INSPECTION	3
WARRANTY	3
ASSISTANCE	3
SERVICE PROCEDURE.....	3
RETURN PROCEDURE	4
SAFETY INSTRUCTIONS	4
TURBO-ICT & BCM-RF-E SET.....	5
GENERAL DESCRIPTION	6
In-flange models.....	7
In-Vacuum models.....	8
MECHANICAL DIMENSIONS AND DRAWINGS.....	9
In-flange models.....	9
In-vacuum models	10
Drawings.....	10
BCM Chassis	11
BCM-RF-E front panel description	12
BCM-RFC rear panel description	13
QUICK CHECK.....	14
Current Transformer Test Device.....	14
Setup 1: Charge measurement, Sample & Hold mode (S&H)	16
Setup 2: Current measurements, Track Continuous mode (T-C)	21
Setup 3: Charge measurements using the embedded calibrated generator (-CAL-FO option), Sample & Hold mode (S&H).....	24
SENSITIVITY OF TURBO-ICT AND BCM-RF-E.....	27
TEMPERATURE DEPENDENCE OF TURBO-ICT AND BCM-RF-E.....	28
GRAPHICAL USER INTERFACE	29
Installation	30
BCM-RF-E communication	31
GUI user guide	32
BCM-RF-E FIRMWARE	34
USB COMMUNICATION WITH THE BCM-RF-E	34
BCM-RF-E I/O AND SWITCHES	38
SPECIFICATIONS.....	39
Charge measurements.....	39

Current measurements.....	39
Input signals, output signals and other interfaces.....	40
BCM-RF-E.....	42
BCM-RFC power supply and fuses.....	42
Connectors and pin allocation	43
RECOMMENDATIONS ABOUT CABLES AND INSTALLATION.....	44
Standard recommendations.....	44
Installation inside a vacuum chamber	45

INITIAL INSPECTION

It is recommended that the shipment be inspected immediately upon delivery. If it is damaged in any way, contact Bergoz Instrumentation or your local distributor. The content of the shipment should be compared to the items listed on the invoice. Any discrepancy should be notified to Bergoz Instrumentation or its local distributor immediately. Unless promptly notified, Bergoz Instrumentation will not be responsible for such discrepancies.

WARRANTY

Bergoz Instrumentation warrants its beam current monitors to operate within specifications under normal use for a period of 12 months from the date of shipment. Spares, repairs and replacement parts are warranted for 90 days. In exercising this warranty, Bergoz Instrumentation will repair, or at its option, replace any product returned to Bergoz Instrumentation or its local distributor within the warranty period, provided that the warrantor's examination discloses that the product is defective due to workmanship or materials and that the defect has not been caused by misuse, disassembly, neglect, use of faulty part, accident or abnormal conditions, repair made by the customer, or operations. Damages caused by ionizing radiations are specifically excluded from the warranty. Bergoz Instrumentation and its local distributors shall not be responsible for any consequential, incidental or special damages.

ASSISTANCE

Assistance in installation, use or calibration of Bergoz Instrumentation beam current monitors is available from Bergoz Instrumentation, 01630 Saint Genis Pouilly, France. It is recommended to send a detailed description of the problem by email to info@bergoz.com.

SERVICE PROCEDURE

Products requiring maintenance should be returned to Bergoz Instrumentation or its local distributor: The purchaser/customer must ask for a RMA (Return Material Authorization) number to Bergoz Instrumentation or its local distributor before return of goods. Bergoz Instrumentation will repair or replace any product under warranty at no charge.

For products in need of repair after the warranty period, Bergoz Instrumentation will assess the technical issue and send a quote to the purchaser/customer. The purchaser/customer must provide a purchase order before repairs can be initiated. Bergoz Instrumentation can issue fixed price quotations for most repairs.

RETURN PROCEDURE

All products returned for repair should include a detailed description of the defect or failure as well as name, phone number and email of a contact person to allow further inquiry. Contact Bergoz Instrumentation or your local distributor to determine where to return the product. Returns must be notified by email prior to shipment.

The shipment of a product under warranty or out of warranty back to the factory is paid by the user/customer, including the customs fees. The return of this repaired product under warranty back to the customer is paid by Bergoz Instrumentation.

Return of product out of warranty should be made prepaid or will be invoiced. Bergoz Instrumentation will not accept freight-collect shipments. Shipments should be made via UPS, FedEx or DHL. Within Europe, the transportation services offered by the national Post Offices can be used. The delivery charges or customs clearance charges arising from the use of other carriers will be charged to the customer.

SAFETY INSTRUCTIONS

This instrument is operated from the mains power supply. For safe operation, it must be grounded by way of the grounding conductor in the power cord. Use only the fuse specified. Do not remove cover panels while the instrument is powered. Do not operate the instrument without the cover panels properly installed.

Chassis originally shipped to U.S. or Canada feature AC mains power entry modules where the Phase is fused and the Neutral unfused, as is the rule.

Chassis to other destinations but U.S. and Canada feature AC mains power entry modules where both Phase and Neutral are fused.

When a chassis with unfused Neutral shall be used outside the U.S. and Canada, fuse configuration must be modified so that both Phase and Neutral will be fused:

The Power entry module must be opened, the Phase fuse must be removed, the fuse holder must be flipped; its reverse side presents two slots where two new fuses must be inserted, one in each slot. The fuses rating must be same as the Phase fuse that was removed.

The Toroid sensor contains materials such as cobalt and iron. Those materials may become radioactive when exposed to high energy particle beams. Follow applicable radiation-safety procedures when the Toroid sensor must be handled.

TURBO-ICT & BCM-RF-E SET

This manual applies to BCM-RF-E revisions 204.4 with firmware 2.4 and above. It does NOT apply to earlier BCM-RF-E revisions or earlier firmware versions. It does not apply to either BCM-IHR-E, BCM-CA-E or BCM-CW-E.

The Turbo-ICT & BCM-RF-E set includes:

- Turbo-ICT
- BCM-RF-E electronics module
- BCM-RFC/xx 19" RF-shielded chassis for BCM-E modules of all versions with power supply and spare power supply
- Turbo-ICT to BCM-RFC chassis interconnect coaxial cable:
 - BCM-Cxx standard interconnect cable in PEX with PTFE connectors
 - or
 - BCM-RHCxx Turbo-ICT rad-tolerant interconnect cable in PEX with PEEK connectors
- Option: BCM-C400-xxx or BCM-C600-xxx CWCT to BCM-RFC chassis interconnect cable for long distances. When provided, each end needs to be connected to a one-meter interconnect cable BCM-C-xxx.
- Option: BCM-RF-RAMP when larger charge range than Turbo-ICT & BCM-RF-E standard range is measured



In-Flange Turbo-ICT and BCM-RF-E set

Turbo-ICT features an aluminum box attached to its side; it contains the FEFA Front-End Filter and Amplifier. When option -CAL-FO has been ordered, another box is attached on the opposite side, containing the FO-triggered Calibrated pulse generator.

BCM-RFC/xx RF shielded chassis is compatible with BCM-CW-E, BCM-IHR-E and BCM-RF-E. BCM-CW-E, BCM-IHR-E and BCM-RF-E electronics modules can be mixed in the same BCM-RFC/xx chassis.

Power supply must however be dimensioned according to power consumption. Please contact Bergoz Instrumentation before adding more BCM modules into a chassis.

GENERAL DESCRIPTION

The Turbo-ICT current sensor and BCM-RF-E electronics receiver perform bunch charge or average current measurements with low noise and high accuracy.

Turbo-ICT combines a current transformer of a new kind and front-end filter and amplifier (FEFA) electronics in one assembly.

The Turbo-ICT is available in two styles: In-flange models or In-vacuum models.

FEFA includes a narrow-band filter, usually centered around 180 MHz, and an amplifier stage. It is powered by the BCM-RF-E electronics via the coaxial interconnect cable.

The input stage of the BCM-RF-E electronics includes a further narrow-band filter centered around the same frequency as the FEFA. This contributes to effective out-of-band signal and noise rejection. The receiver stage implements a logarithmic RF amplifier to achieve 90 dB input dynamic range and 10 MHz output bandwidth.

The BCM-RF-E allows two modes of operation:

- Sample & Hold mode (S&H): This mode is suitable for single bunch charge measurements with pulse repetition rates up to 1 MHz. The BCM-RF-E output provides a DC voltage logarithmically proportional to the input charge.
- Track-Continuous mode (T-C): This mode is suitable for CW beam or long macropulse average current measurements. The BCM-RF-E output provides the logarithmic envelope of the Turbo-ICT signal with 10 MHz bandwidth allowing to observe beam current variations with 35 ns rise time (10%-90%).

Both modes are described in this manual.

The BCM-RF-E embeds a PIC microcontroller that can be used for BCM-RF-E configuration and digital data read-out. Please note that the digital data read-out is not calibrated. It should not be used for high precision measurements.

The communication is done via specific commands send over a USB connection, e.g. as used by the BCM-CW-E graphical user interface (GUI). Details on the GUI and USB communication are described later in this manual.

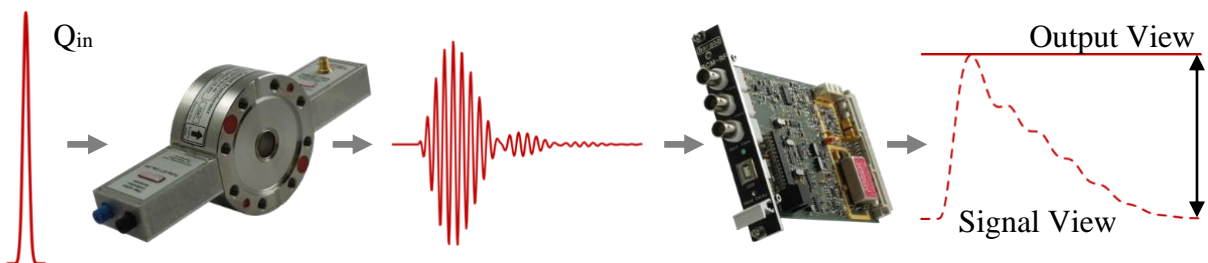

The BCM-RF-E microcontroller is factory-loaded with calibration constants corresponding to its associated Turbo-ICT and the operating mode (T-C or S&H) is preset according to the purchase order. The calibration constants (see section 'Sensitivity of the Turbo-ICT and BCM-RF-E' for details) can also be found in the Calibration Report provided with the Turbo-ICT and BCM-RF-E.

WARNING: Jumper configuration & PIC configuration

At the time of delivery, the BCM-RF-E is in the "Ex-factory" configuration. Jumpers and PIC microcontroller are configured according to the order. Do not change those settings until the BCM-RF system is familiar.

In-flange models

In-flange models are current transformers whose cores are embedded in a pair of vacuum flanges. Flanges are Conflat.

These current transformers are UHV compatible at least to 1e-9 mbar. Soap or alcohol cleaning before installation is however recommended. To reach pressure down to 1e-11 mbar, adequate pumping and cleaning, e.g. plasma, are required.

Turbo-ICT temperature should never exceed 100°C (212°F) at any time during bake out or operation.

Turbo-ICT wall current break ("gap") is a ceramic ring (Al₂O₃ 99.7%) brazed onto two Kovar transition sleeves.

Standard models are made from AISI 304 steel, AISI 316LN is available on option.

In-flange Turbo-ICT part numbers follow below syntax:

In-flange Turbo-ICT	
Turbo-ICT-	Turbo-ICT sensor, noise of 20 fC/pulse
-CFx"-	x" is the CF flanges OD [inch]
-xx.x-	xx.x is the sensor ID [mm]
-xx-	xx is the sensor axial length [mm]
-UHV-	UHV: Sensor UHV compatible with brazed ceramic wall current break
	- As delivered down to 1e-9 mbar
	- After adequate cleaning down to 1e-11 mbar
Example: Turbo-ICT-CF6"-60.4-40-UHV	
Options for In-flange Turbo-ICT	
Turbo2-	Replace Turbo1, noise of 10 fC/pulse
-CALFO-	Calibrated pulse generator (charge given in calibration report), FO triggered
-ARB#xxx-	In-flange Turbo-ICT sensor with special arbitrary aperture
-316LN-	In-flange Turbo-ICT sensor in AISI316LN instead of 304
-H	Radiation-tolerant sensor option, all components R.I.>6

In-Vacuum models

In-vacuum models are Turbo-ICTs whose cores and FEFA electronics are embedded inside a stainless-steel box. This box is vacuum insulated with a Viton gasket.

Turbo-ICT-VAC are made to be installed in vacuum enclosures. They are vacuum compatible down to 1e-7 mbar.

When an In-vacuum model is installed inside a vacuum enclosure, the coaxial cable going to the BCM-RF-E should leave the enclosure via an isolated vacuum feedthrough (see page 45).

In-vacuum Turbo-ICTs have the below syntax:

In-Vacuum Turbo-ICT	
Turbo-ICT- -VAC- -xxx-	Turbo-ICT sensor, noise of 20 fC/pulse In-vacuum ICT xxx is the sensor aperture [mm]
Example: ICT-VAC-055-Turbo1	
Options for In-Vacuum Turbo-ICT	
Turbo2-	Replace Turbo1, noise of 10 fC/pulse



In-vacuum Turbo-ICT

MECHANICAL DIMENSIONS AND DRAWINGS

In-flange models

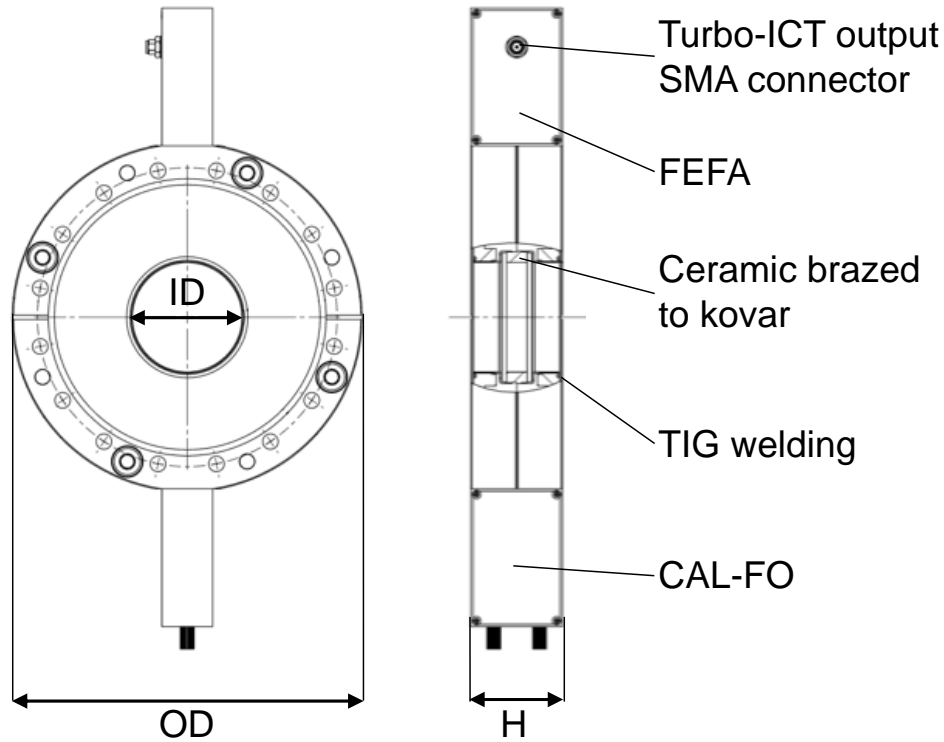

In-flange Turbo-ICT sensor order code	Flange OD (inch)	Pipe OD (inch)	Mating flange	ID (mm)	H (mm)
Turbo-ICT-CF3"3/8-22.2-40-UHV	3.375"	1"	DN/NW50CF	22.2	40
Turbo-ICT-CF4"1/2-34.9-40-UHV	4.5"	1.5"	DN/NW63CF	34.9	40
Turbo-ICT-CF4"1/2-38.0-40-UHV	4.5"	40 mm	DN/NW63CF	38.0	40
Turbo-ICT-CF6"-47.7-40-UHV	6"	2"	DN/NW100CF	47.7	40
Turbo-ICT-CF6"-60.4-40-UHV	6"	2.5"	DN/NW100CF	60.4	40
Turbo-ICT-CF6"3/4-96.0-40-UHV	6.75"	4"	DN/NW130CF	96.0	40
or Turbo-ICT-CF8"-96.0-40-UHV	8"		DN160/NW150CF		
Turbo-ICT-CF10"-147.6-40-UHV	10"	6"	DN/NW200CF	147.6	40
Turbo-ICT-CF12"-198.4-40-UHV	12"	8"	DN/NW250CF	198.4	40

In-vacuum models

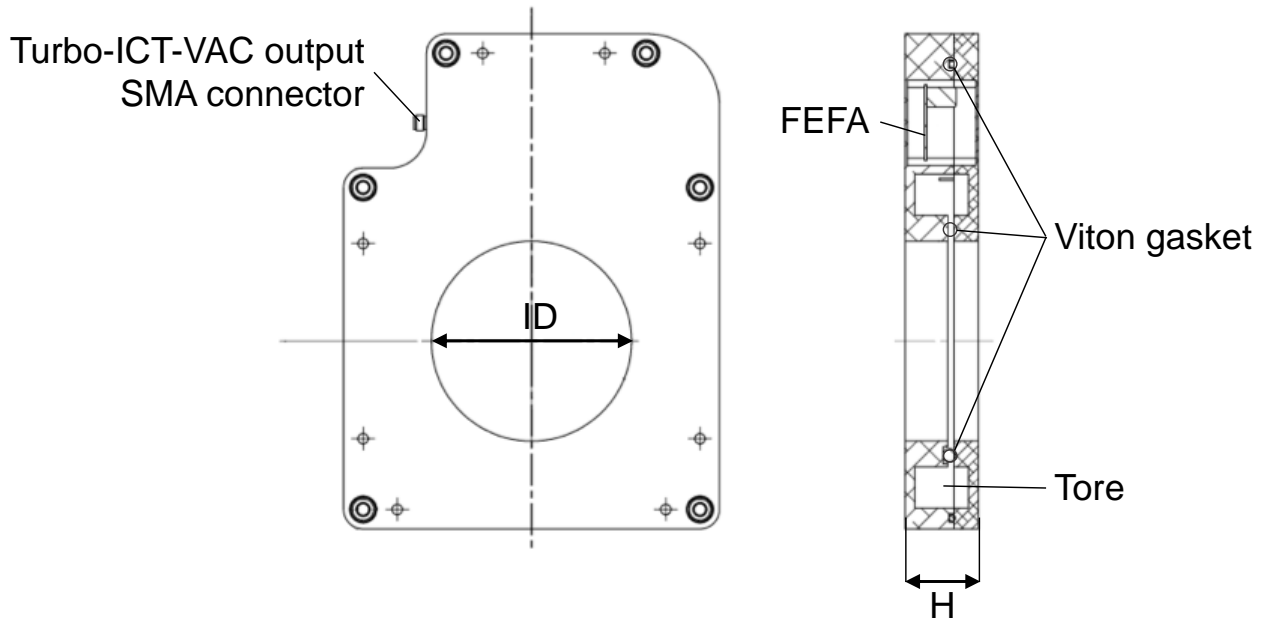

In-vacuum Turbo-ICT sensor order code	Outer dimensions (mm)	ID (mm)	H (mm)
Turbo-ICT-VAC-055	175 x 126	55.0	30
Turbo-ICT-VAC-082	203 x 154	82.0	30

Drawings

Drawings in .pdf can be found on our website:

www.bergoz.com :: Turbo-ICT & BCM-RF-E :: Downloads :: Technical drawings

Dimensions missing on the website can be obtained by contacting info@bergoz.com

BCM Chassis

The BCM-RFC/xx chassis is based on a 19" Schroff rackable RF chassis.

Bin dimensions: 3U x 84F

Schroff reference: Europac Lab HF/RF #20845-283

The BCM-RFC/xx can be wired with up to 8 BCM-RF-E stations, xx being the number of wired stations (one BCM-RF-E module per station).

Unwired stations are masked with RF-shielded blank panels.

BCM-RFC/xx outer dimensions:

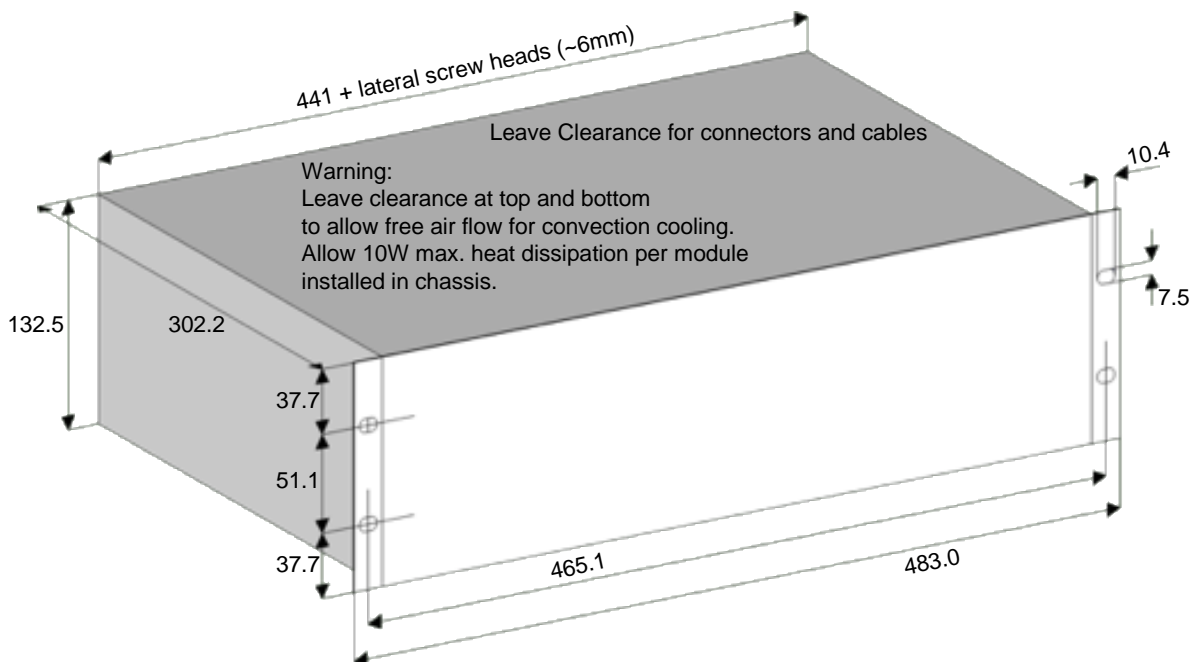

BCM-RF-E front panel description



Signal View:

Logarithmic envelope of the Turbo-ICT signal (50 Ω or 1 M Ω readout).

Output View:

Output voltage logarithmically proportional to the input charge (in S&H mode) or to the average input current (in T-C mode) (1 M Ω readout).

Hold View: (S&H mode only)

Rising edge indicates approximately the hold time, i.e. the time when the BCM-RF-E starts to hold the voltage of the logarithmic envelop (50 Ω readout).¹

Front panel LED:

Flashes in S&H mode when a trigger occurs. Permanently ON in T-C mode.

USB connector type B:

Data readout and remote control.

Hold Delay front panel trimmer:

Used to fine adjust the hold time when the PIC microcontroller is not installed. When the PIC is installed, the hold delay is controlled via USB.

¹ To ensure a perfect coincidence between Signal View and Hold View, you should use coaxial cables of equal length and equal characteristics. Otherwise, a phase adjustment may be needed on your oscilloscope, to correct for cable- or oscilloscope-induced timing errors.

BCM-RFC rear panel description



Remote control:

DB9 – pin 6: ADC TTL trigger output, i.e. trigger signal output to synchronize the user's ADC with the BCM-RF-E timing.

The other DB9 pins are not connected.

BCM Input:

BCM-RF-E input signal from the Turbo-ICT FEFA.

BCM Output:

Output voltage logarithmically proportional to the input charge (in S&H mode) or to the average input current (in T-C mode) (1 M Ω readout).

Trigger in: (S&H mode only)

External trigger input (50 Ω terminated).

QUICK CHECK

Before installation in the accelerator, different bench tests can be performed to get familiar with the Turbo-ICT and the BCM-RF-E Depending on the signal generators at disposal (RF source and/or pulse generator), different quick check procedures can be executed:

- Bunch charge measurement in S&H mode, using a fast pulse generator
- CW beam current or long macropulse current measurement in T-C mode, using an RF signal generator
- Calibrated pulse charge measurement in S&H mode, using the optional attached calibrated pulse generator. Option -CAL-FO is required.

Current Transformer Test Device

When performing measurements using a pulse generator or RF signal generator, as described in quick check setups 1 and 2, a test fixture is required to transmit the signal through the Turbo-ICT aperture. This test fixture and the Turbo-ICT flanges form a coaxial transmission line. Like this impedance mismatch remains at acceptable levels and the input signal is maintained. It is not recommended to pass a simple wire through the Turbo-ICT aperture. The test fixture is not required for quick check setup 3 when the attached calibrated pulse generator (option -CAL-FO) is used for generating the input signal.

Turbo-ICT test fixture:

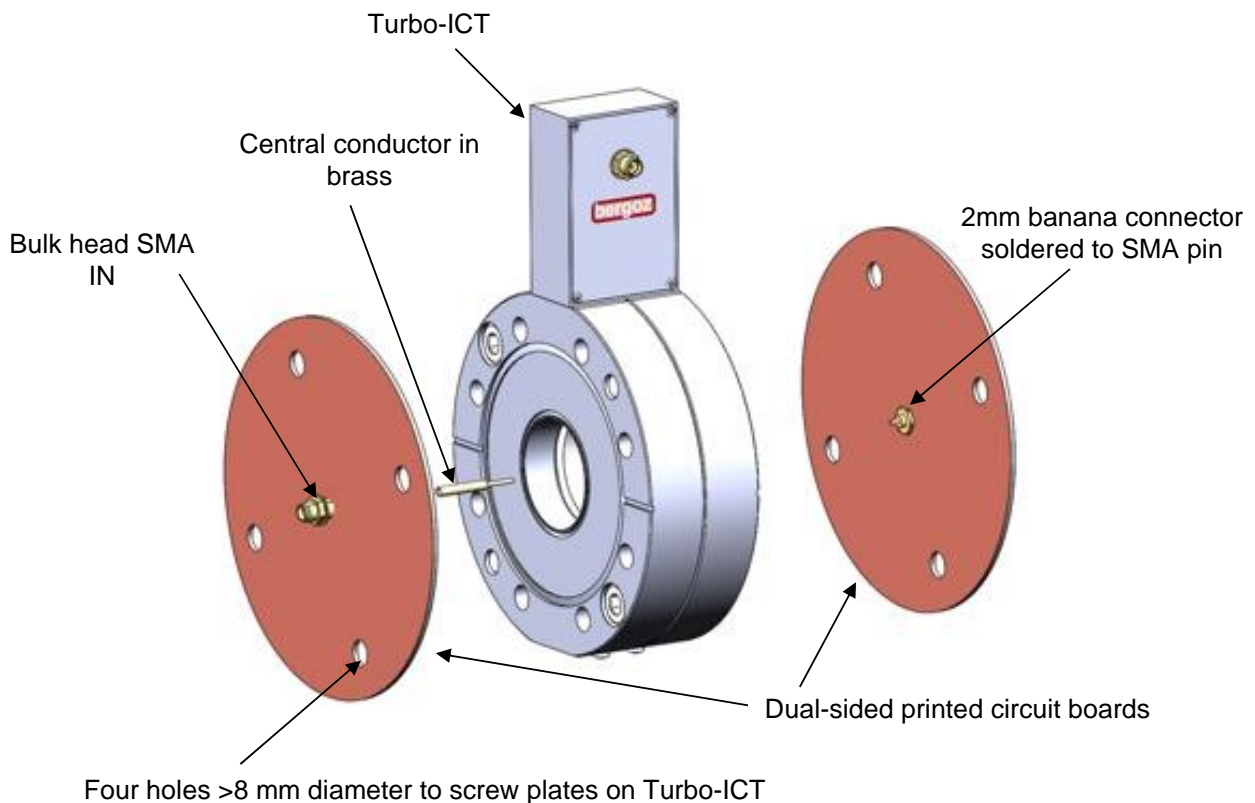

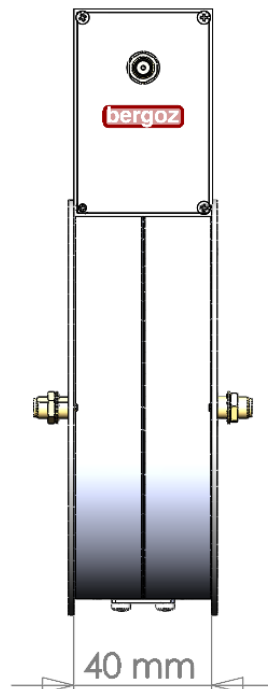
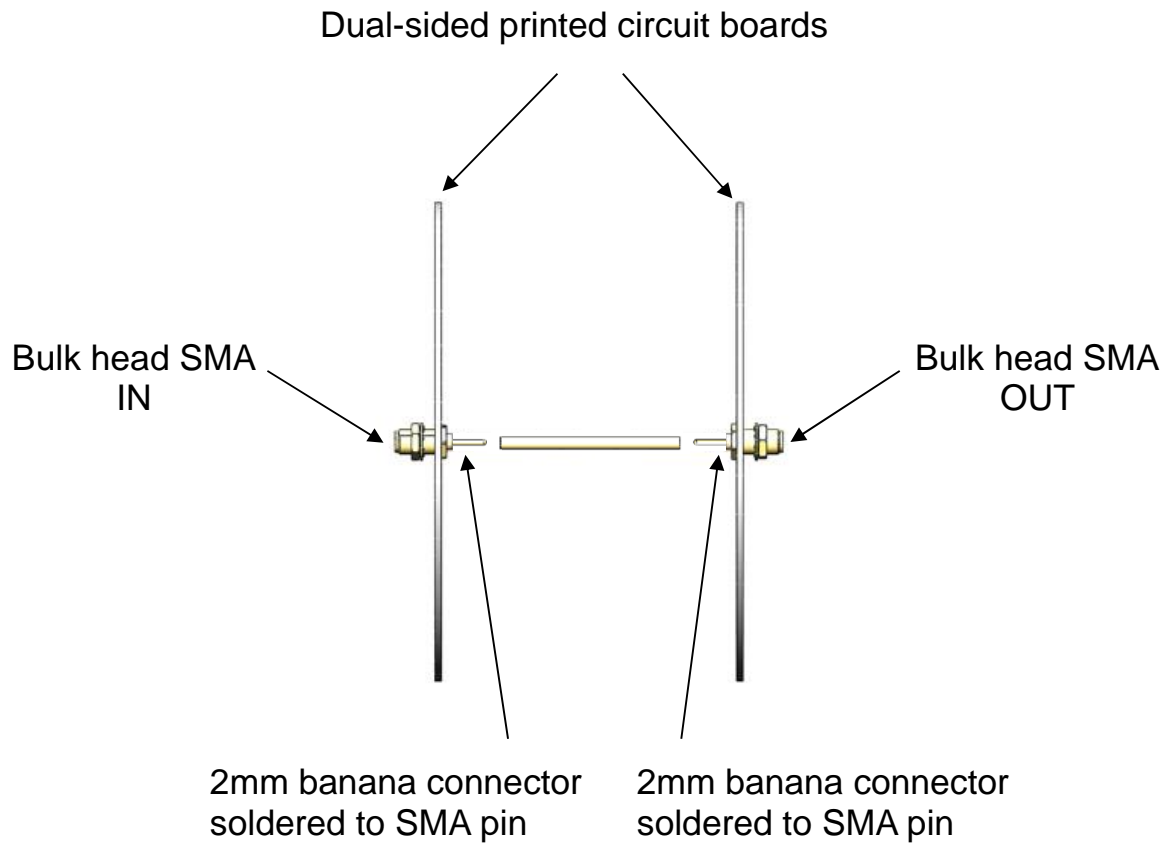

Setup 1: Charge measurement, Sample & Hold mode (S&H)

What is needed:

- Turbo-ICT
- Current Transformer test fixture (see page 14 for description)
- BCM-RF-E electronics module
- BCM-RFC/xx chassis
- Turbo-ICT to BCM-RFC/xx coaxial interconnect cable
- Fast pulse generator: <math>< 500\text{ ps}</math> fwhm,
~5 V peak (use attenuators if necessary),
<math>< 1\text{ MHz}</math> repetition rate or externally triggered,
The pulse polarity is not relevant.
- 4-channel oscilloscope with 500 MHz bandwidth or higher
- Voltmeter
- Short (1–2 m) coaxial cables and SMA-BNC adapters
- BNC T-adapter
- 50 Ω load

Setup

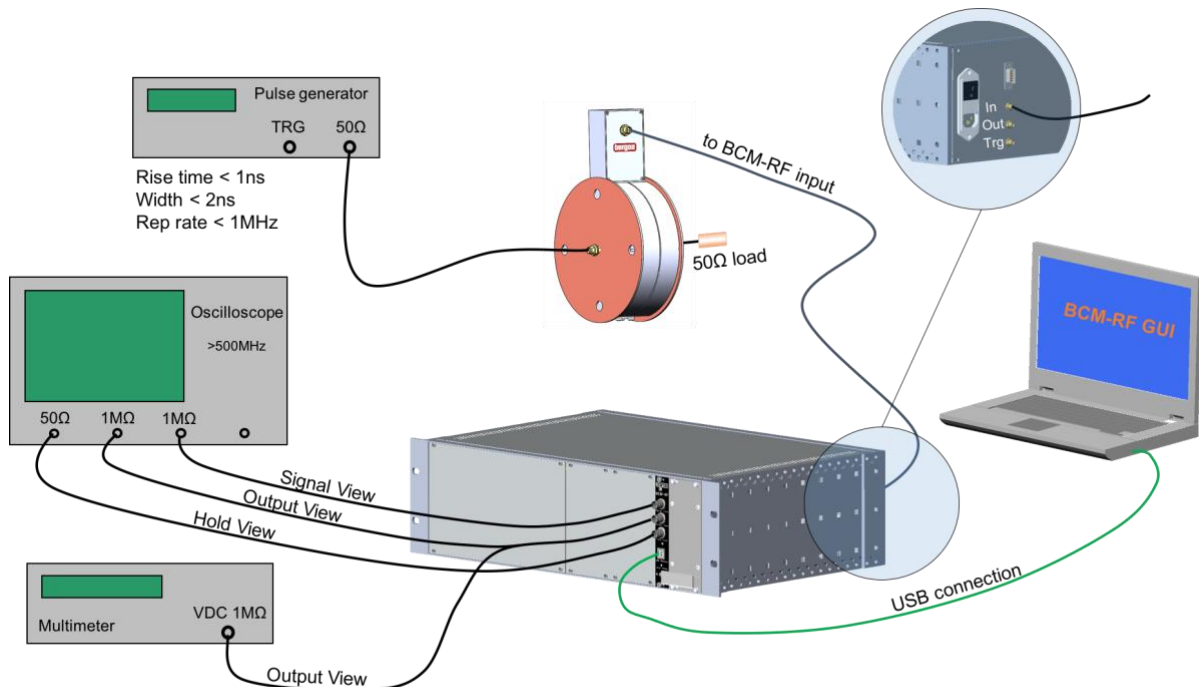

Steps

- 1) At time of shipment, the AC mains voltage is set according to the country of destination. A label on the power supply units shows the AC voltage it is set up to. Check that it corresponds to the local AC mains voltage. Turn OFF the chassis power switch and connect the AC mains to the chassis.
- 2) Mount the Current Transformer test fixture onto the Turbo-ICT.
- 3) Connect the Turbo-ICT FEFA output to the "BCM Input" on the chassis rear panel using the coaxial interconnect cable. WARNING: when the chassis is powered, +15 Vdc is present on the "BCM Input" to feed the Turbo-ICT FEFA.
- 4) Connect the pulse generator output to the Current Transformer test fixture input.
- 5) Connect the 50 Ω load to the Current Transformer test fixture output.
- 6) Connect the BCM-RF-E Output View (front panel) to the voltmeter 1 M Ω input and to an oscilloscope 1 M Ω channel, using the BNC T-adapter.
- 7) Connect the BCM-RF-E Signal View (front panel) to another oscilloscope 1 M Ω channel.
- 8) Connect the BCM-RF-E Hold View (front panel) to the oscilloscope 50 Ω channel.
- 9) Connect the BCM-RF-E USB connector to a PC on which the BCM-RF system Graphical User Interface has been installed (See the Graphical User Interface section page 29 for details about the installation and the determination of the COM port to be used).
- 10) Turn ON the BCM-RFC/xx chassis power switch.
- 11) On the PC, open the BCM-RF system GUI, select the COM port to which the BCM-RF-E is connected, start the BCM-RF system GUI and set the following parameters:
 - Sample and Hold mode (S&H)
 - On Board trigger mode

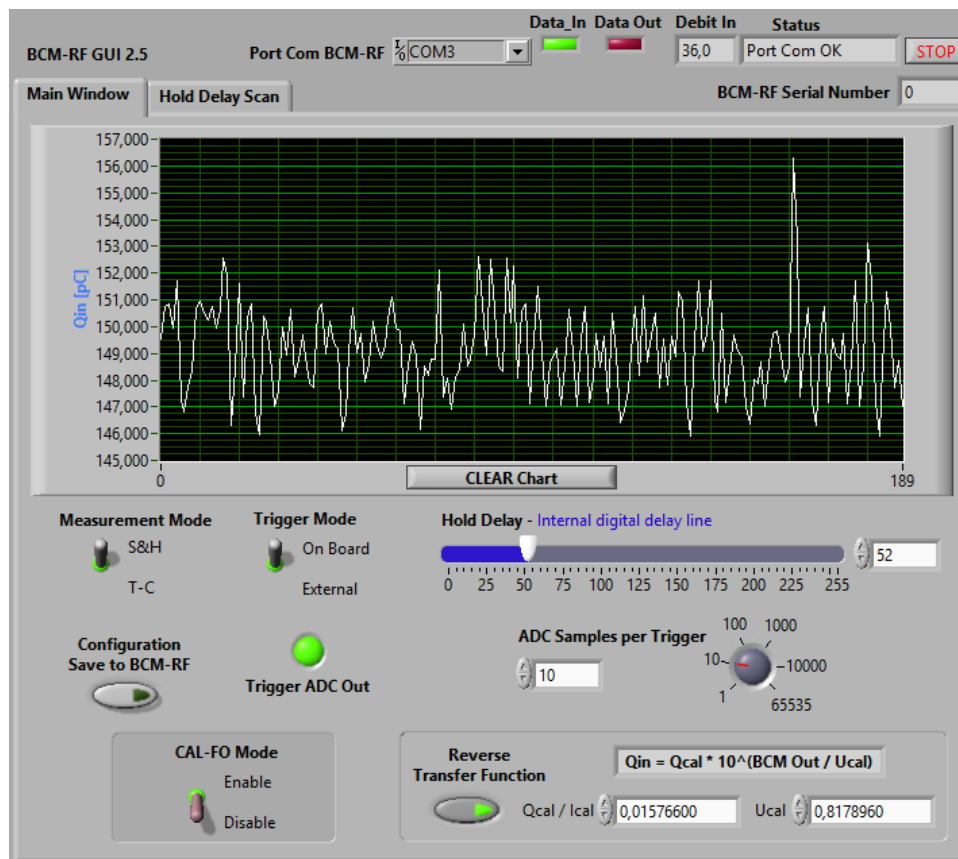

12) Turn ON the pulse generator

The data acquisition starts automatically. The BCM-RF-E output voltage is displayed on the GUI's graph. The corresponding input charge can be displayed by clicking on the Reverse Transfer Function button, provided that the PIC microcontroller was factory-loaded with the calibration constants of the Turbo-ICT being used (see the Sensitivity of Turbo-ICT & BCM-RF-E section for details).

The BCM-RF-E output voltage displayed on the GUI's graph can be compared to the voltage measured by the voltmeter connected to the BCM-RF-E front panel BNC connector Output View.

Note: The BCM-RF-E output voltage is held constant for up to 100 ms after the pulse. If the pulse repetition rate is <10 Hz, the voltmeter must be triggered, e.g. using the BCM-RF-E ADC TRG Out, pin 6 of the rear panel DB9. Its acquisition must occur during the 100 ms following the trigger.

13) Observe the waveforms on the oscilloscope.

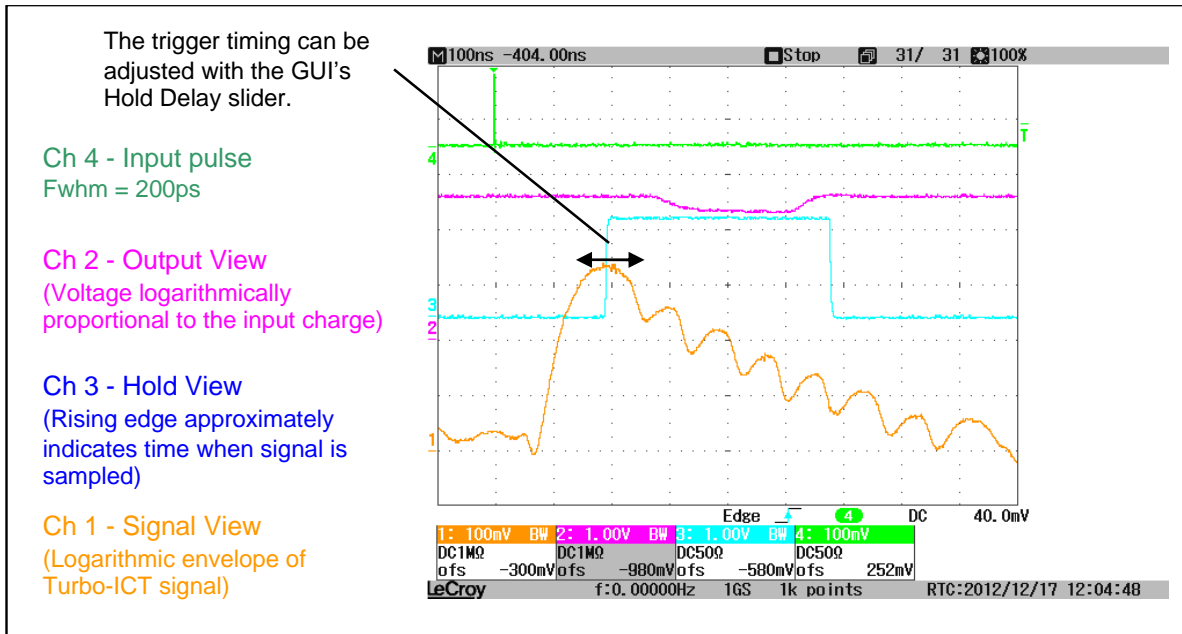

Channel 4 (green) shows the short input pulse which goes through the Turbo-ICT aperture.

Channel 2 (magenta) shows the BCM-RF-E Output. This voltage is held constant for up to 100 ms after the pulse.

Channel 3 (cyan) shows the BCM-RF-E Hold View. The rising edge of this signal approximately indicates the time when the signal is sampled.

Channel 1 (orange) shows the BCM-RF-E Signal View. This signal is the logarithmic envelope of the signal coming from the Turbo-ICT FEFA output.

14) Trigger timing adjustment

The BCM-RF-E Signal View shows the logarithmic envelope of the signal coming from the Turbo-ICT FEFA output. Its apex is proportional to the input pulse charge logarithm. The BCM-RF-E Hold View output shows the trigger timing. Its rising edge indicates approximately the time when the output signal is sampled.

To make a correct measurement of the input pulse charge, the trigger timing must be adjusted so that the trigger rising edge coincides with the Signal View apex.

Two methods can be used to properly adjust the hold time:

1. Measure the BCM-RF-E output voltage on the voltmeter and fine adjust the GUI's Hold Delay slider until the maximum voltage reading occurs. To make sure that the apex is close, it is recommended to visualize Signal View and Hold View waveforms on the oscilloscope while performing the Hold Delay adjustment.
2. Use the GUI's Hold Delay Scan utility. Perform a Hold Delay scan and note the Hold Delay value corresponding to the output voltage apex. Then adjust the Hold Delay slider of the GUI's main window to this value.

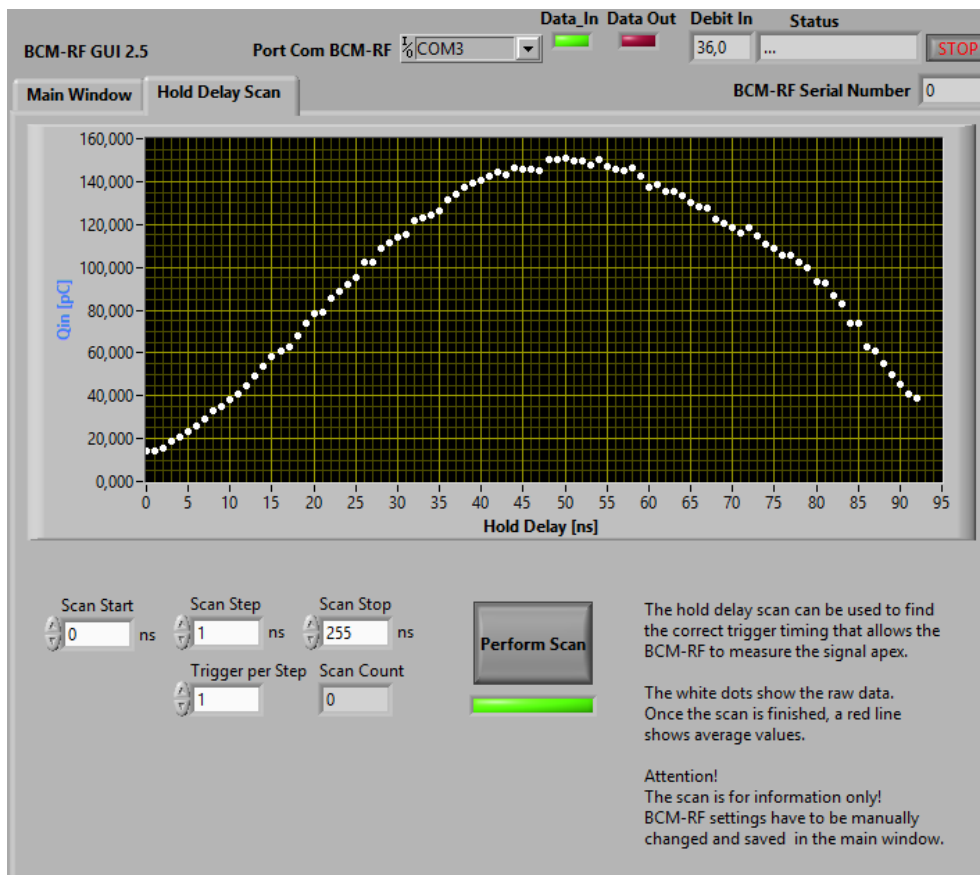

Setup 2: Current measurements, Track Continuous mode (T-C)

What is needed:

- Turbo-ICT
- Current Transformer test fixture (see page 14 for description)
- BCM-RF-E electronics module
- BCM-RFC/xx chassis
- Turbo-ICT to BCM-RFC/xx coaxial interconnect cable
- RF signal generator
- 4-channel oscilloscope with 500 MHz bandwidth or higher
- Voltmeter
- Short (1–2 m) coaxial cables and SMA-BNC adapters.
- BNC T-adaptor
- 50 Ω load

Setup

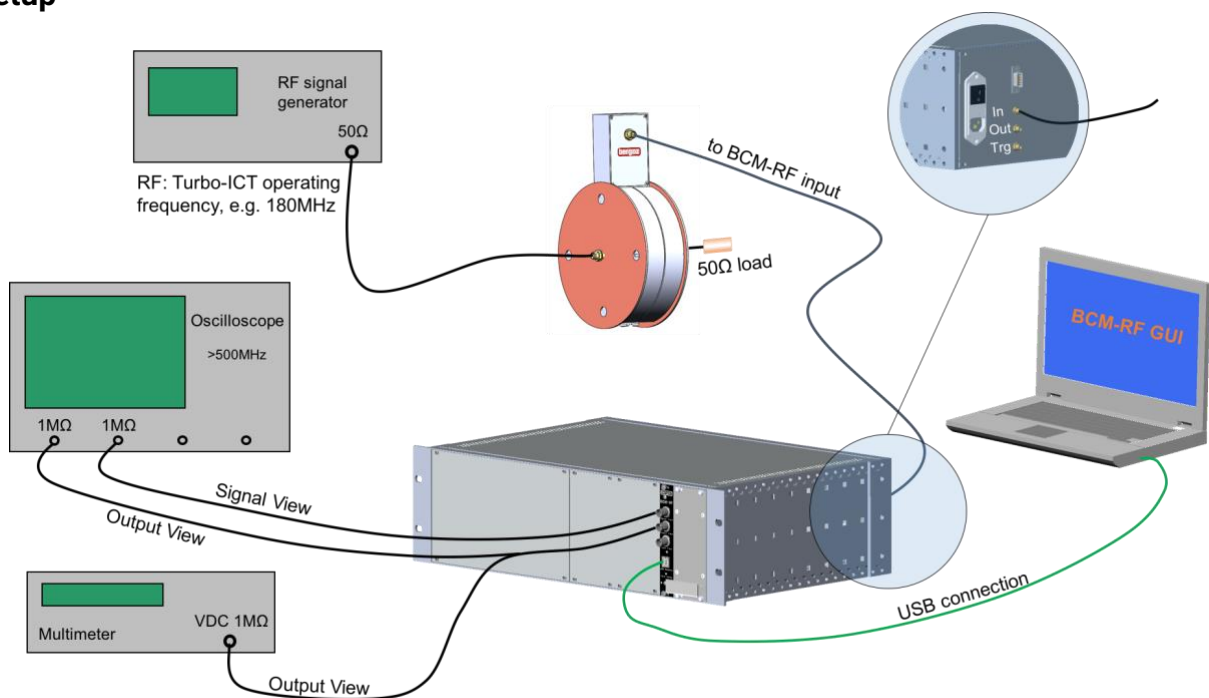

Steps

- 1) At time of shipment, the AC mains voltage is set according to the country of destination. A label on the power supply units shows the AC voltage it is set up to. Check that it corresponds to the local AC mains voltage. Turn OFF the chassis power switch and connect the AC mains to the chassis.
- 2) Mount the Current Transformer test fixture onto the Turbo-ICT.

- 3) Connect the Turbo-ICT FEFA output to the "BCM Input" on the chassis rear panel using the coaxial interconnect cable. **WARNING:** +15 Vdc is present on the "BCM Input" connector to feed the Turbo-ICT FEFA when the chassis is powered.
- 4) Connect the RF signal generator output to the Current Transformer test fixture input.
- 5) Connect a 50 Ω load to the Current Transformer test fixture output.
- 6) Connect the BCM-RF-E Output View (front panel) to the voltmeter (1 MΩ input) and to the oscilloscope (1 MΩ input).
- 7) Connect the BCM-RF-E Signal View (front panel) to the oscilloscope (1 MΩ input).
- 8) Connect the BCM-RF-E USB connector to a PC on which the BCM-RF system Graphical User Interface has been installed (See the Graphical User Interface section page 29 for details about the installation and the determination of the COM port to be used).
- 9) Turn ON the BCM-RFC/xx chassis power switch.
- 10) On the PC, open the BCM-RF system GUI, select the COM port to which the BCM-RF-E is connected, start the BCM-RF system GUI and set the following parameters:
 - Track Continuous mode (T-C)
(Trigger Mode and Hold Delay slider are not used)

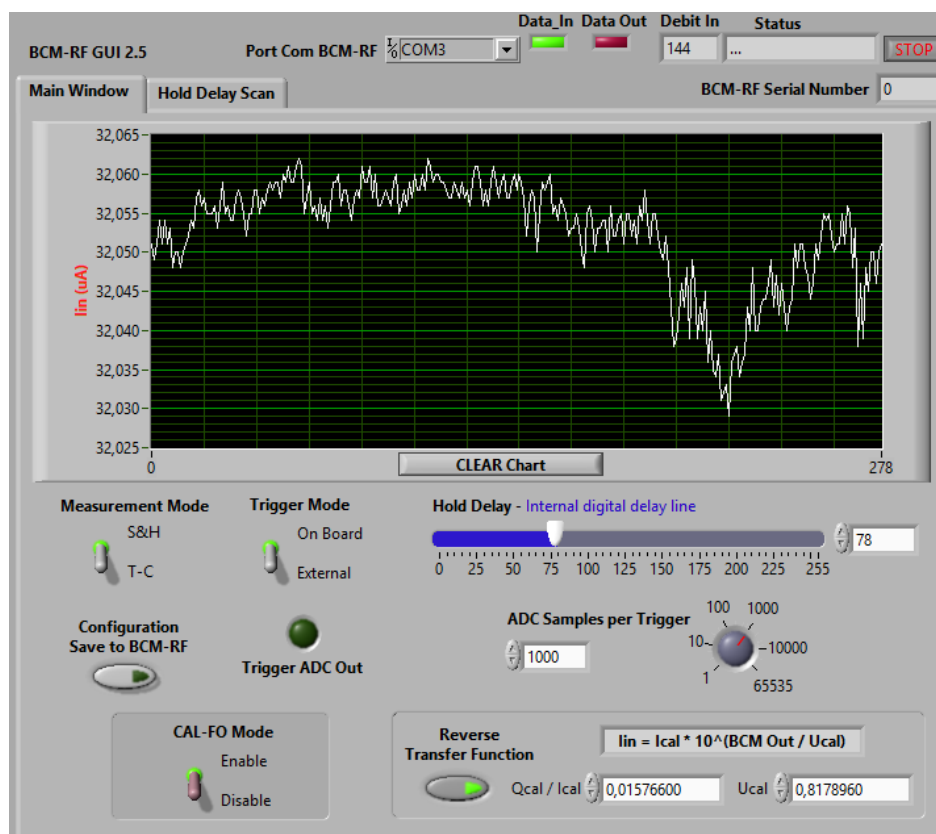

- 11) Turn ON the RF signal generator:
 - Set RF frequency to the Turbo-ICT & BCM-RF-E operating frequency, e.g. 180 MHz
 - Amplitude: -20 dBm

The data acquisition starts automatically. The BCM-RF-E output voltage is displayed on the GUI's graph. The corresponding input current can be displayed by clicking on the Reverse Transfer Function button, provided that the PIC microcontroller was factory-loaded with the calibration constants of the Turbo-ICT being used (see the Sensitivity of Turbo-ICT & BCM-RF-E section for details).

The BCM-RF-E output voltage displayed on the GUI's graph can be compared to the voltage measured by the voltmeter connected to the BCM-RF-E front panel output.

- 12) Change the amplitude of the RF signal generator sinewave and compare the BCM-RF-E output voltages measured by the GUI and by the voltmeter.
- 13) Waveform and reaction time.

Observe on the oscilloscope the input sine waveform provided by the RF signal generator and the Output View signal from the BCM-RF-E front panel.

The Output View signal is proportional to the logarithm of the current provided by the RF signal generator.

BCM-RF-E reaction time can be observed by creating a quick, i.e. <10 ns, step in the sine amplitude. The reaction time is the time span from the input amplitude change until the output value rises by 50%. It is about 110 ns.

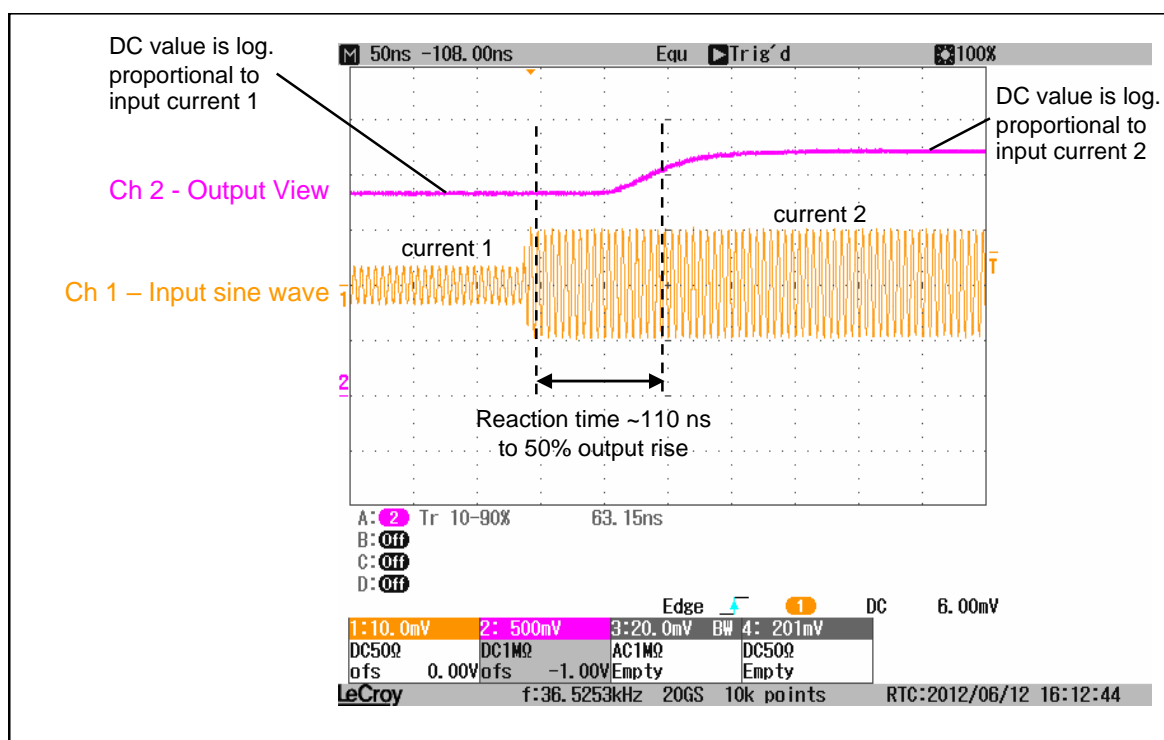

Setup 3: Charge measurements using the embedded calibrated generator (-CAL-FO option), Sample & Hold mode (S&H)

What is needed:

- Turbo-ICT with -CAL-FO option
- Optical signal generator
- BCM-RF-E electronics module
- BCM-RFC/xx chassis
- Turbo-ICT to BCM-RFC/xx coaxial interconnect cable
- 4-channel oscilloscope with 500 MHz bandwidth or higher
- Short (1–2 m) coaxial cables and SMA-BNC adapters.

Setup

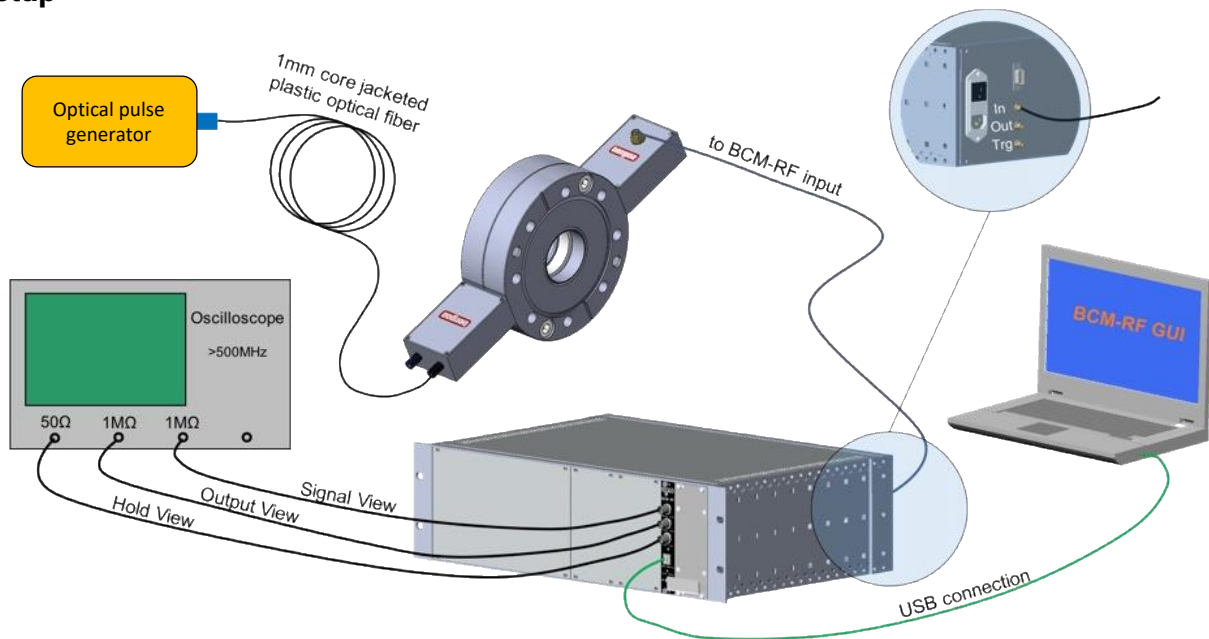

Steps

- 1) At time of shipment, the AC mains voltage is set according to the country of destination. A label on the power supply units shows the AC voltage it is set up to. Check that it corresponds to the local AC mains voltage. Turn OFF the chassis power switch and connect the AC mains to the chassis.
- 2) Connect the Optical Signal Generator to the CAL-FO input (black) with a 1 mm core jacketed plastic optical fiber.
- 3) Connect the Turbo-ICT FEFA output to the "BCM Input" (on the BCM-RFC/xx chassis rear panel) using the coaxial interconnect cable. **WARNING:** +15 Vdc is present on the "BCM Input" to feed the Turbo-ICT FEFA when the BCM-RF-E is powered.
- 4) Connect the BCM-RF-E Output View (front panel) to the oscilloscope (1 MΩ input).

- 5) Connect the BCM-RF-E Signal View (front panel) to the oscilloscope (1 MΩ input).
- 6) Connect the BCM-RF-E Hold View (front panel) to the oscilloscope (50 Ω input).
- 7) Connect the BCM-RF-E USB connector to a PC on which the BCM-RF system Graphical User Interface has been installed (See the Graphical User Interface section page 29 for details about the installation and the determination of the COM port to be used).
- 8) On the PC, open the BCM-RF system GUI, select the COM port to which the BCM-RF-E is connected, start the BCM-RF system GUI and set the following parameters:
 - CAL-FO Mode enable
(Measurement Mode, Trigger Mode and Hold Delay become inactive)



When CAL-FO Mode is enabled, the BCM-RF-E operates in Sample & Hold mode and uses the on-board trigger. The BCM-RF system GUI thus automatically triggers after a pulse has been created by the signal generator module.

The Hold Delay value for a pulse generated by the CAL-FO pulse generator is factory-measured and saved in the PIC microcontroller. When CAL-FO Mode is enabled, this Hold Delay value is automatically loaded. The Hold Delay may need to be adjusted and saved to the BCM-RF-E if the cable connecting Turbo-ICT and BCM-RF-E changes.

- 9) Press the push-button on the Bergoz Optical Signal Generator to trigger the CAL-FO. A pulse of fixed parameters will be injected into the Turbo-ICT sensor. The GUI triggers and displays on its graph the corresponding BCM-RF-E output voltage. The related input charge can be displayed by clicking on the Reverse Transfer Function button, provided that the PIC microcontroller was factory-loaded with the calibration constants of the Turbo-ICT being used (see the Sensitivity of Turbo-ICT & BCM-RF-E section for details).
- 10) Observe the waveforms on the oscilloscope.

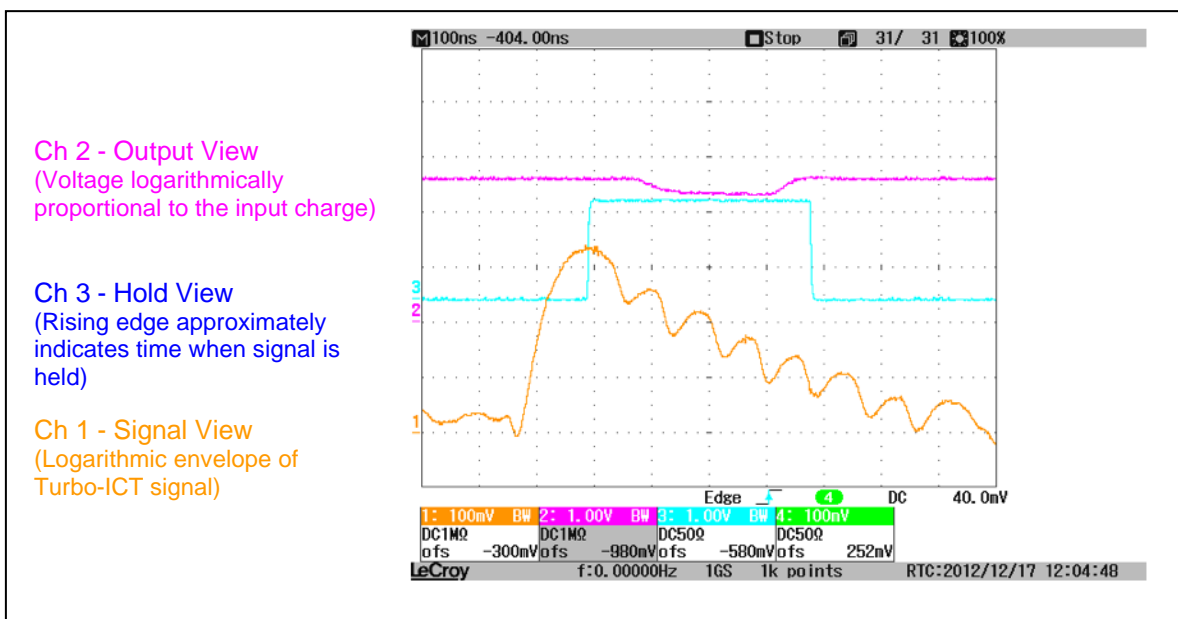

Channel 2 (magenta) shows the BCM-RF-E Output. This voltage is held constant for up to 100 ms after the pulse.

Channel 3 (cyan) shows the BCM-RF-E Hold View. The rising edge of this signal approximately indicates the time when the signal is sampled.

Channel 1 (orange) shows the BCM-RF-E Signal View. This signal is the logarithmic envelope of the signal coming from the Turbo-ICT FEFA output.

The BCM-RF-E Signal View output gives the logarithmic envelope of the signal coming from the Turbo-ICT FEFA output. Its apex is proportional to the logarithm of the input pulse charge.

The BCM-RF-E Hold View output shows the trigger timing. Its rising edge indicates approximately the time when the output signal is sampled.

To make a correct measurement of the input pulse charge, the trigger timing must be adjusted so that the rising edge of the trigger signal coincides with the Signal View apex. When CAL-FO Mode is enabled, the correct hold delay value is automatically loaded, which was factory-saved in the microcontroller. The near coincidence of the Hold View signal rising edge and the Signal View apex can be observed on the oscilloscope.

SENSITIVITY OF TURBO-ICT AND BCM-RF-E

In Sample-and-Hold Mode (S&H mode) the BCM-RF-E measures charges of individual particle bunches. Its output signal is a voltage logarithmically proportional to the input bunch charge. In Track-Continuous Mode (T-C mode) the BCM-RF-E measures the average current of the particle beam. Its output signal is a voltage logarithmically proportional to the average input current.

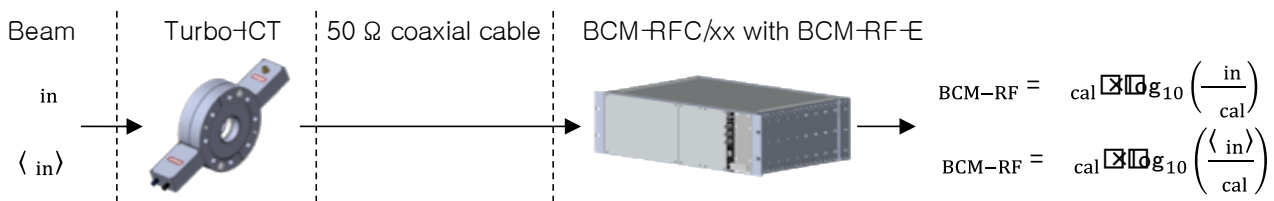

The sensitivity is defined as the reverse transfer function of the complete signal chain consisting of the Turbo-ICT, the interconnect cable and the BCM-RF-E.

The sensitivity of a given combination of Turbo-ICT, interconnect cable and BCM-RF-E is provided in the Calibration Report. Each combination has its own sensitivity. Consequently, the sensitivity must be re-measured or re-calculated every time an item is changed.

Reverse transfer function (sensitivity):

$$Q_{\text{in}} = Q_{\text{cal}} \times 10^{\left(\frac{U_{\text{BCM-RF}}}{U_{\text{cal}}} \right)} \quad (\text{S\&H mode})$$

$$I_{\text{in}} = I_{\text{cal}} \times 10^{\left(\frac{U_{\text{BCM-RF}}}{U_{\text{cal}}} \right)} \quad (\text{T - C mode})$$

The calibration constants U_{cal} , I_{cal} and Q_{cal} are factory-measured and provided in the Calibration Report. They are also saved in the BCM-RF-E PIC microcontroller. U_{cal} is measured in Volts, I_{cal} is measured in micro-Amperes and Q_{cal} is measured in pico-Coulombs.

During calibration, the attenuation of the coaxial interconnect cable between Turbo-ICT and BCM-RF-E is taken into account. If a different cable is used in the accelerator compared to the one used during the calibration, corrections to the sensitivity must be applied by the user.

The real cable attenuation can be obtained, for example, by network analyzer measurements of the transmission coefficient at the operating frequency. The full signal attenuation from the Turbo-ICT output connector to the BCM-RF-E input connector must be taken into account.

The cable attenuation only affects Q_{cal} and I_{cal} . Hence, the correction is just an additional factor applied to the reverse transfer function:

$$Q_{in} = Q_{cal} \times \frac{\text{Real Cable Att.}}{\text{Cable Att. used for calibration}} \times 10^{\left(\frac{U_{BCM-RF}}{U_{cal}}\right)} \text{ (S\&H mode)}$$

$$I_{in} = I_{cal} \times \frac{\text{Real Cable Att.}}{\text{Cable Att. used for calibration}} \times 10^{\left(\frac{U_{BCM-RF}}{U_{cal}}\right)} \text{ (T - C mode)}$$

As long as the applied correction remains small, overall performance will not be affected. But in case of larger corrections, noise floor and saturation point might shift. Non-linearities might change as well. In such a case, Bergoz Instrumentation can provide further advice.

TEMPERATURE DEPENDENCE OF TURBO-ICT AND BCM-RF-E

The signals delivered by the Turbo-ICT and the BCM-RF-E depend weakly on temperature. The corresponding temperature coefficients are factory-measured and provided on the sheet "Temperature Dependence" delivered with the product.

The necessary corrections can be applied to the measured voltage:

$$U_{BCM-RF,corr} = U_{BCM-RF,meas} - c_{BCM-RF}^U (T_{BCM-RF} - T_{Cal}) - c_{Turbo-ICT}^U (T_{Turbo-ICT} - T_{Cal})$$

The corrected voltage is then used to determine the charge or current.

Or the uncorrected voltage is used to determine charge or current. And the corrections are applied to this charge or current:

$$\Rightarrow Q_{corr} \approx Q_{meas} \times \left(1 - c_{BCM-RF}^Q (T_{BCM-RF} - T_{Cal})\right) \times \left(1 - c_{Turbo-ICT}^Q (T_{Turbo-ICT} - T_{Cal})\right)$$

$$\Rightarrow I_{corr} \approx I_{meas} \times \left(1 - c_{BCM-RF}^I (T_{BCM-RF} - T_{Cal})\right) \times \left(1 - c_{Turbo-ICT}^I (T_{Turbo-ICT} - T_{Cal})\right)$$

- c_{BCM-RF}^U = Temperature coefficient of the output voltage with respect to changes of the BCM-RF-E temperature
- $c_{Turbo-ICT}^U$ = Temperature coefficient of the output voltage with respect to changes of the Turbo-ICT temperature
- c_{BCM-RF}^Q = Temperature coefficient of the measured charge with respect to changes of the BCM-RF-E temperature
- $c_{Turbo-ICT}^Q$ = Temperature coefficient of the measured charge with respect to changes of the Turbo-ICT temperature

$C_{\text{BCM-RF}}^I$	=	Temperature coefficient of the measured current with respect to changes of the BCM-RF-E temperature
$C_{\text{Turbo-ICT}}^I$	=	Temperature coefficient of the measured current with respect to changes of the Turbo-ICT temperature
$T_{\text{BCM-RF}}$	=	Ambient temperature outside the BCM-RFC/xx chassis
$T_{\text{Turbo-ICT}}$	=	Ambient temperature at the Turbo-ICT location
T_{Cal}	=	Ambient temperature during BCM-RF-E and Turbo-ICT calibration

GRAPHICAL USER INTERFACE

Bergoz Instrumentation provides a GUI to communicate with the BCM-RF-E via USB. It allows to control the BCM-RF-E operating modes and settings, and to acquire the BCM-RF-E output signal. This software was developed with LabVIEW 2014. It is provided as a Microsoft Windows compatible executable file. The LabVIEW .vi file can be obtained upon request to info@bergoz.com.

Operating systems supported:

Any Microsoft Windows version that can run LabVIEW 2014 or the corresponding run time environment and the NI-VISA driver package, e.g. Windows XP, Vista, 7, 8, 10 or 11.

To use other operating systems, please ask for the LabVIEW .vi file.

The installer package of the BCM-RF system GUI contains the LabVIEW run time environment and the VISA drivers. They can also be obtained from the National Instruments web site.

The Microchip USB CDC serial driver might be required on Windows systems to communicate with the BCM-RF-E. This driver is part of the Microchip Libraries for Applications (USB package of Legacy MLA). It is also provided with the BCM-RF-E or can be obtained from Bergoz Instrumentation upon request to info@bergoz.com.

Installation

- 1) At time of delivery, a USB stick is attached to the last page of the printed manual accompanying the Turbo-ICT / BCM-RF-E. Open the folder containing the BCM-RF system GUI Installer.
- 2) Run the Setup executable file and proceed with the installation.
- 3) The BCM-RF system GUI application (.exe) is installed at the location specified during installation. If necessary, also the LabVIEW 2014 run-time environment and the NI VISA drivers are installed.
- 4) The Microchip USB CDC serial driver is provided on the USB stick in a compressed ZIP archive. Un-compress this archive. A folder will be created containing the files necessary for driver installation.
- 5) Right-click on the file "mchpcdc.inf" and choose "Install".

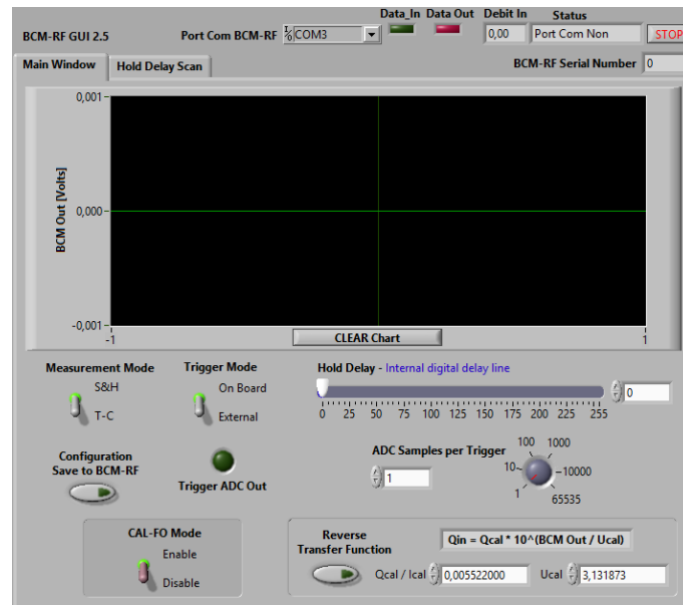

BCM-RF-E communication

- 1) Connect the USB cable from the BCM-RF-E front panel USB port to the PC.
- 2) Windows automatically recognizes the device and loads the USB CDC serial driver.
- 3) In the device manager, look for the serial COM port number associated to the BCM-RF-E.

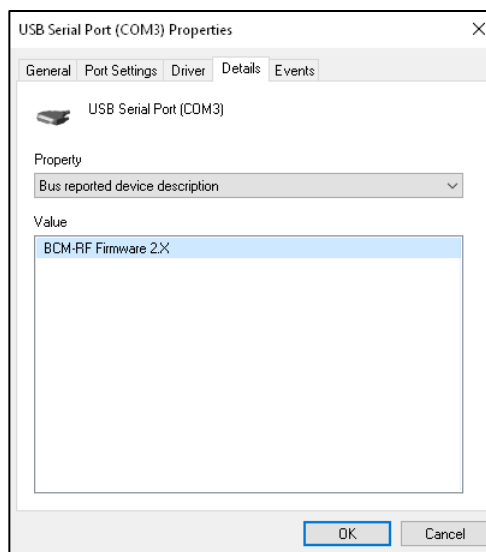
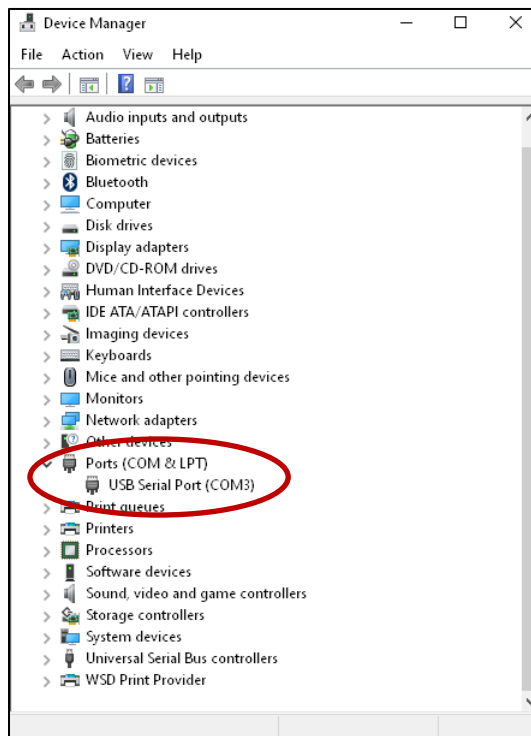

- 4) . Open the GUI and enter the COM port in the GUI field called "BCM-CW-E COM PORT".
- 5) Run the GUI, communication with BCM-RF-E starts.

GUI user guide

Two windows are selectable on the GUI front panel:

- 1) Main Window
- 2) Hold Delay Scan

1) Main Window

The Main Window is where all BCM-RF-E controls can be found. In the upper part is a graph displaying the BCM-RF-E output voltage as measured by the on-board PIC microcontroller (uncalibrated). This voltage can be converted into input charge or input current when the Reverse Transfer Function is activated.

Measurement Mode:

- S&H: Sample and Hold mode measures the bunch charge. It works with single bunches up to 2 MHz repetition rate. This mode needs a trigger, either on-board or external.
- T-C: Track Continuous mode measures the average beam current with a 10 MHz bandwidth, i.e., with 35 ns risetime / falltime to beam current change. This mode is a free running process and does not use any trigger.

Trigger Mode:

- On-board: The BCM-RF-E embeds an on-board trigger synchronized to the incoming Turbo-ICT signal.
- External: The BCM-RF-E can be triggered by an external TTL rising edge. The "Trigger in" SMA connector is located on the BCM-RFC/xx chassis rear panel.

Trigger ADC Out:

This indicator flashes when a new signal arrives. It is only available in S&H mode.

Hold Delay:

The Hold Delay sets the BCM-RF-E trigger timing. The trigger rising edge must coincide with the apex of the input signal's logarithmic envelope. The Hold Delay needs to be precisely adjusted each time the setup is modified.

The Hold Delay value is adjustable from 0 to 255 ns in steps of 1 ns.

CAL-FO Mode:

CAL-FO Mode is a preset mode intended to be used with the embedded calibrated pulse generator (-CAL-FO option). When enabled, the GUI's controls are set in a particular configuration:

- Measurement Mode: S&H
- Trigger Mode: On Board
- Hold Delay: Ex-factory, hold delay value used for the CAL-FO calibration measurements. In some cases, may need to be adjusted to properly trigger on the resonance apex.

"Hold Delay", "ADC Samples per Trigger", "Reverse Transfer Function", "Configuration Save to BCM-RF-E" and the "Hold Delay Scan" remain accessible in CAL-FO mode.

ADC Samples per Trigger:

Defines the number of voltages samples averaged by the PIC before sending a value (from 1 to 65535). In T-C mode, this effectively reduces output bandwidth and noise. In S&H mode, this results in an averaging of consecutive beam pulses.

Reverse Transfer Function:

When the GUI is set to S&H measurement mode, the Reverse Transfer Function calculates the input bunch charge from the BCM-RF-E output voltage based on the calibration constants Ucal and Qcal. The graph then displays the input charge in pico-Coulombs.

When the GUI is set to T-C measurement mode, the Reverse Transfer Function calculates the average input current from the BCM-RF-E output voltage based on the calibration constants Ucal and Ical. The graph then displays the average input current in micro-Amperes.

Configuration Save to BCM-RF-E:

Stores the current BCM-RF-E settings in the BCM-RF-E microcontroller EPROM. The settings saved to the EEPROM will be restored when the BCM-RF-E is switched on.

2) Hold Delay Scan

The Hold Delay Scan window allows to perform a Hold Delay scan which determines the Hold Delay value corresponding to the output voltage apex. Once the scan has finished, this value needs to be transferred manually to the Hold Delay slider settings on the GUI's Main Window.

Scan Start, Scan Stop, Scan Step and number of Trigger per Step are adjustable.

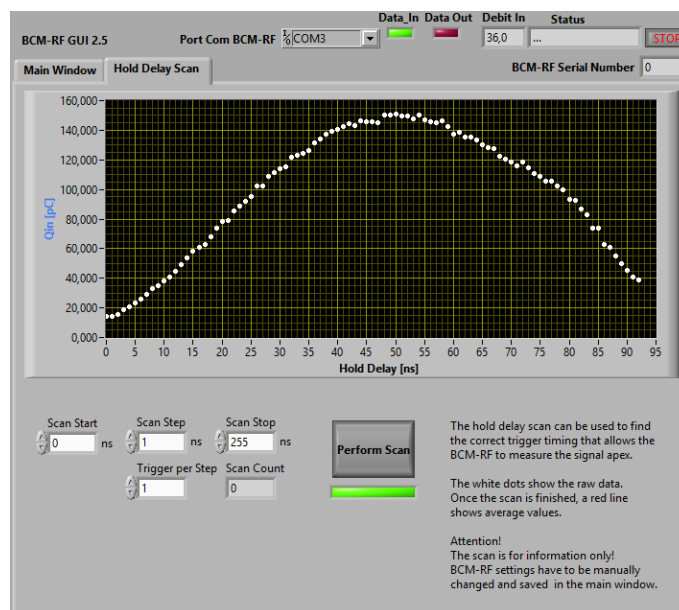

BCM-RF-E FIRMWARE

The BCM-RF-E embeds a PIC18F2458 microcontroller from Microchip Technology Inc. This microcontroller includes a 12bit ADC and allows USB communication.

The BCM-RF-E firmware is written in C using the MPLAB 8.9 IDE and the MPLAB C18 compiler, both available from the Microchip website: www.microchip.com.

The firmware code can be obtained from Bergoz Instrumentation upon request. Users can freely modify the code to fit at best their own application.

To program and debug the microcontroller, remove the BCM-RF-E cover shield and connect an ICD3 Microchip In-circuit debugger to the RJ11-R connector (see I/O AND SWITCHES section). BCM-XTD card extender may be required to extend the BCM-RF-E out of its BCM-RFC chassis.

USB COMMUNICATION WITH THE BCM-RF-E

Communication between host PC and BCM-RF-E is performed via the microcontroller's built-in USB to serial converter. The connection is done with a USB cable. But for data transmission, the BCM-RF-E looks being attached to a serial port of the host.

The Microchip USB CDC serial driver might be required on Windows systems to communicate with the BCM-RF-E USB port. This driver is part of the Microchip Libraries for Applications (USB package of Legacy MLA). It is also provided with the BCM-RF system or can be obtained from Bergoz Instrumentation upon request.

The BCM-RF-E uses the Communication Devices Class USB protocol in POLLING mode. All data is transmitted as character strings.

A general frame used to send a command from the host to the BCM-RF-E looks like this:

1 char Frame type	1 char Frame number	1 char Write / Read indicator	4 char Value	2 char Termination
'A' to 'Z'	'0' to '9'	': ' write data to PIC or '?' demand data from PIC	0000 to FFFF HEX value	\n\n0 Ascii(10) Ascii(0)

Examples: "D0:0005\n\n0", "D0?\n\n0"

If data is demanded from the BCM-RF-E using the read indicator '?', the four value characters can be omitted.

It is possible to concatenate a few frames in a single line send to the BCM-RF-E. It is sufficient that each frame ends by \0 (ascii(0)) instead of \n\n0 (ascii(10) ascii(0)).

Warning!

The BCM-RF-E firmware does not always disregard wrongly formatted frames. It is mandatory that the value send to the BCM-RF-E is exactly four characters long and contains only hexadecimal numbers. Otherwise, the BCM-RF-E might misbehave.

A general frame received by the host from the BCM-RF-E looks like this:

1 char Frame type	1 char Frame number	1 char Separator	4 char Counter	1 char Separator	8 char Value	2 char Termination
'A' to 'Z'	'0' to '9'	':'	0000 to FFFF HEX value	'='	00000000 to FFFFFFFF HEX value	\n\n0 Ascii(10) Ascii(0)

Example: "D0:0123=00000005\n\n0"

In T-C mode, the analog BCM-RF-E output signal is periodically sampled by the microcontroller's 12bit ADC. The sampled value is then automatically sent to the host via USB.

In S&H mode, when the microcontroller receives a new trigger event via the ADC_TRG_OUT signal, the analog BCM-RF-E output signal is sampled by the microcontroller's 12bit ADC. The sampled value and a "new trigger" frame are then automatically sent to the host via USB.

Frames automatically sent by the BCM-RF-E to the host:

Frame type	Description	Example
A	BCM-RF-E's ADC sampled voltage in microvolts If the reverse function is activated (see frame type "M") data will be sent as femtocoulombs (S&H mode) or nanoamperes (T-C mode)	A0:0123=00123ABC\n\n0
!	New trigger frame (only send in S&H mode)	!0:0123=00000001\n\n0

This table describes the write commands that can be send by the host to the BCM-RF-E. These commands change the BCM-RF-E configuration. The BCM-RF-E will not send a response:

Command	Description	Command Frame (omitting termination)	Comments
D	Set on-board's digital delay line value in nanoseconds	D0:00xx	"xx" must be an integer number in HEX format within the range "00" to "FF"
E	Save BCM-RF-E configuration to microcontroller's EEPROM	E0:0001	
I	Set BCM-RF-E switch configuration	I0:000x	Single bits of "x" are used to switch modes: Bit0 = 0 => use external trigger Bit0 = 1 => use internal trigger Bit1 = 0 => T-C mode

			Bit1 = 1 => S-H mode Bit2 = 0 => Internal clock off (for T-C mode) Bit2 = 1 => Internal clock on (for S-H mode) Bit3 = 0 => Digital Delay line on, Front panel trimmer off Bit3 = 1 => Digital Delay line off, Front panel trimmer on
K	Activate CAL-FO mode (optional)	K0:0001 K0:0000	on off
M	Activate microcontroller's reverse function algorithm For information on data formats, see description of the data frame "A"	M0:0001 M0:0000	on off
T	Set number of ADC samples used for averaging	T0:xxxx	"xxxx" must be an integer number in HEX format within the range "0000" to "FFFF"
V	Set calibration constant Qcal (in picocoulombs) or Ical (in microamperes)	V1:yyyy and V0:xxxx	The calibration constants are transmitted as hexa-decimal representations of IEEE754 encoded 32bit floating point numbers. The command frame V1:yyyy sends the upper 16bit. The command frame V0:xxxx sends the lower 16bit. Example: Decimal: Qcal = 0.015766 Binary of IEEE754 encoded 32bit float: Qcal = 00111100100000010010011110110011 HEX of IEEE754 encoded 32bit float: Qcal = 3C8127B3 The frames V1:3C81 and V0:27B3 need to be send.
W	Set calibration constant Ucal (in volts)	W1:yyyy and W0:xxxx	see above

This table describes the read commands that can be sent by the host to the BCM-RF-E and the corresponding response frames send by the BCM-RF-E back to the host. These commands do not change the BCM-RF-E on-board switch configuration:

Command	Description	Command Frame (omitting termination)	Response Frame (omitting termination)	Comments
D	Read on-board's digital delay line value in nanoseconds	D0?	D0:zzzz=000000xx	"xx" is an integer number in HEX format within the range "00" to "FF"

I	Read BCM-RF-E switch configuration	I0?	I0:zzzz=0000000x	See previous table for a description of the data format.
K	Read state of CAL-FO mode (optional)	K0?	K0:zzzz=00000001 K0:zzzz=00000000	on off
M	Read state of reverse function algorithm	M0?	M0:zzzz=00000001 M0:zzzz=00000000	on off
S	Read BCM-RF-E serial number	S0?	S0:zzzz=xxxxxxx	"xxxxxxx" is an integer number in HEX format within the range "00000000" and "FFFFFFF"
T	Read number of ADC samples used for averaging	T0?	T0:zzzz=0000xxxx	"xxxx" is an integer number in HEX format within the range "0000" and "FFFF"
V	Read calibration constant Qcal (in picocoulombs) or Ical (in microamperes)	V0?	V1:zzzz=0000xxxx and V0:zzzz=0000yyyy	See previous table for a description of the data format. Note that the response frame "V0" contains the upper 16bit and the response frame "V1" contains the lower 16bit.
W	Read calibration constant Ucal (in volts)	W0?	W1:zzzz=0000xxxx and W0:zzzz=0000yyyy	See previous table for a description of the data format. Note that the response frame "W0" contains the upper 16bit and the response frame "W1" contains the lower 16bit.
IDN	Read the BCM-CW-E identifier string	IDN? or *IDN?	<arb. string>	The response is a string of arbitrary format, e.g. "Bergoz, BCM-CW, S/N 000, FW 1.0"

"zzzz" is a counter ranging from 0000 to FFFF which is incremented each time the BCM-RF-E tries to send data. After the counter reached the value FFFF it will be reset to 0000.

BCM-RF-E I/O AND SWITCHES

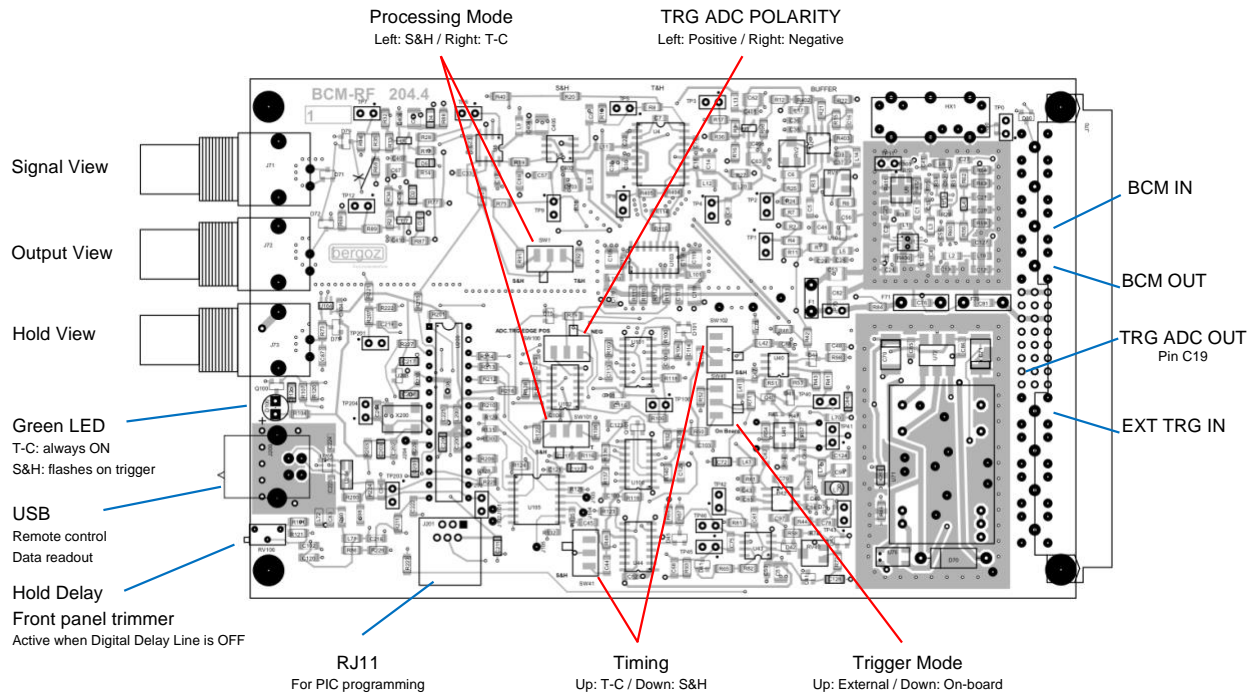

SPECIFICATIONS

Typical performance measured with Turbo2 option:

Charge measurements

BCM-RF-E mode	S&H
Input charge	300 pC max (higher without front-end amplifier)
Measurement range	500 fC ... 300 pC
Bunch repetition rate	Single bunch up to 1 MHz
Output voltage	0 V ... 5 V, logarithmically proportional to the beam charge
Reaction time	500 ns to > 99% final value
Noise	10 fC rms or 1% of charge (whichever is higher)
Non-linearity	2%
Time response	Hold till next trigger or 100 ms maximum
Trigger	On-board or External

Current measurements

BCM-RF-E mode	T-C
Measurement range	0.5 uA ... 3 mA (higher without front-end amplifier)
Beam RF	10 MHz ... 350 MHz
Output voltage	0 V ... +5 V, logarithmically proportional to the beam current
Risetime	< 70 ns
Reaction time	100 ns
Noise	0.1 μ A rms or 1% of current (whichever is higher)
Non-linearity	~2%
Time response	Reports current variations with 10 MHz bandwidth

Input signals, output signals and other interfaces

BCM-RF-E Front Panel



Signal View: BNC connector, waveform to be read by oscilloscope (50 Ω or 1 M Ω)

Voltage range -0.1 V ... 1 V (50 Ω)
 -0.2 V ... 2 V (1 M Ω)

Output View: BNC Connector, DC voltage stable for 100 ms or until next trigger

Voltage range -1 V ... 5 V
Negative voltage may be observed due to noise at very low signal levels.

Readout electronics requirements:

Input impedance \geq 500 k Ω
Resolution \leq 1 mV

To allow for a short settling time in S&H mode, data acquisition shall start earliest 500 ns after the BCM-RF-E has triggered.

Hold View: BNC connector, waveform to be read by oscilloscope (50 Ω)
Voltage range 0 V ... 2 V

USB: Type B connector, compatible to USB 2.0 standard

Hold Delay: 10 turns potentiometer
0 ns ... 200 ns adjustable hold delay range

BCM-RFC Rear Panel



Remote control: DB9 connector
Pin 6: TTL output (5 V into high impedance)
All other DB9 pins are not connected

BCM Input: SMA connector, to be connected to Turbo-ICT-FEFA 50 Ω terminated. Attention! To power the FEFA +15Vdc are present on this output port. Permanent damage may occur if any other equipment than a Turbo-ICT or a RAMP are attached to this port.

BCM Output: SMA connector, DC voltage stable for 100 ms or until next trigger
Voltage range -1 V ... 5 V
Negative voltages may be observed due to noise at very low signal levels

Readout electronics requirements:
Input impedance $\geq 500 \text{ k}\Omega$
Resolution $\leq 1 \text{ mV}$
To allow for a short settling time in S&H mode, data acquisition shall start earliest 500 ns after the BCM-RF-E has triggered.

Trigger in: SMA connector, BCM-RF-E external trigger input
50 Ω terminated
Trigger signal requirements:
Positive pulse starting at 0 V
Amplitude 2.5 V ... 5 V
Length $\geq 100 \text{ ns}$
Rise time $\leq 10 \text{ ns}$

BCM-RF-E

Rear module connector	DIN 41612-M / 24+8 male, with 1.0/2.4 coaxial inserts
Power consumption	+15 V, 170 mA / -15 V, 110 mA (Turbo-ICT connected)
Card size	3U x 4F, i.e. Eurosize 100 x 160 mm, 20 mm wide
Chassis size	3U x 19"

BCM-RFC power supply and fuses

The mains voltage is factory set according to the front panel label. This label should be removed or replaced when the mains voltage selection is changed.

Type	5U 15-15 modular plug-in ± 15 V linear power supply ²
Manufacturer	Delta Elektronika, 4300A Zierikzee, The Netherlands
Output voltage	± 15 V, 200 mA
Mains voltage	jumper selectable, 110, 220 Vac, 50-60 Hz tested at 90 Vac, 50/60 Hz for 100 Vac Japanese mains voltage
Mains voltage selector	located under the power supply block
Card size	3U x 10F, i.e. Eurosize 100 x 160 mm, 50 mm wide
Back-panel connector	power supply mains is wired to an IEC connector via EMI/RFI filter and fuse

Fuse type

Number of 5U 15-15 PS	Mains 110 Vac	Mains 220 Vac
1	400 mA	200 mA
2	800 mA	400 mA
4	1.6 A	800 mA
6	3.2 A	1.6 A

² http://www.delta-elektronika.nl/upload/MAN_5U15-15.pdf

Connectors and pin allocation

BCM-RF-E Front panel BNC connectors					
RF-Chassis Rear SMA connectors					
DB9 female connector on BCM-RFC rear panel					
DIN41612M BCM-RF-E module rear connector					
INPUT SIGNALS					
BCM-RF-E Input	BCM Input	B8 *		SMA1	
OUTPUT SIGNALS					
BCM-RF-E output	BCM Output	B11*		SMA2	
ADC Trigger TTL output pos/neg edge	TRG.ADC.OUT	C19	DB9,6		
BNC front-panel MONITORING					
Input signal after log. demodulation	Signal View				BNC 1
BCM-RF-E Output	Output View				BNC 2
Hold clock (on rising edge)	Hold View				BNC 3
EXTERNAL TRIGGER INPUT					
External trigger input 50 Ω, pos. edge > 2 V	EXT.TRG.IN	B22*		SMA3	
POWER SUPPLY					
+ (8...15) V	+15 V	A13 B13 C13			
- (8...15) V	-15 V	A15 B15 C15			
Common	COM	A14 B14 C14			

* coaxial insert 1.0/2.3 type

RECOMMENDATIONS ABOUT CABLES AND INSTALLATION

Standard recommendations

Turbo-ICT and BCM-RF-E system performance are measured and guaranteed when a Bergoz Instrumentation-supplied interconnect cable BCM-C/xx or BCM-RHC/xx is used. It is double-shielded radiation tolerant coaxial cable to reject RFI. It is fitted at each end by two CMC common-mode chokes for EMI rejection:

- MnZn ferrite core for high-frequency >500 MHz rejection;
- Iron-based nanocrystalline core with soft B-H loop for low frequency rejection.

Unnecessary intermediate bulkheads should be avoided. When for practical reasons bulkheads must be used, e.g., on patch-panels, it is preferable that the bulkhead body is isolated from ground. On either side of the patch-panel a set of two CMC common-mode chokes should be the installed on the cable. This is required to assure EMI rejection.

SMA plug connectors at both ends of a Bergoz Instrumentation-supplied cable feature different dielectric types depending on cable reference:

- Standard BCM-C/xx cable is fitted with PTFE (Teflon) dielectric SMA plugs at both ends. PTFE radiation tolerance R.I.~2 (source H. Schoenbacher CERN Yellow Books).
- Radiation-tolerant BCM-RHC/xx cable is fitted with PEEK (Victrex) dielectric SMA plugs at both ends. PEEK radiation tolerance R.I.>7 (same source).

BCM-RF-E system, i.e., chassis and modules should as much as possible be kept away from high power RF equipment, klystrons, cavities.

If the user procures the Turbo-ICT interconnect cable from a source other than Bergoz Instrumentation, cable should be double shielded, connectors should be chosen carefully according to the cable specifications, connector dielectric should conform to the radiation environment, appropriate common-mode chokes should be installed at each end of every cable segment. A cable segment is any section of cable between two grounded connectors or bulkheads, for example through a grounded patch panel.

Cable and connectors manufacturer's instructions should be followed meticulously. If the cable assembly is subcontracted, subcontractors should be informed of the extreme reliability expected from these cables. Transmission and reflections of each cable should be controlled before installation with a vector network analyzer, over a frequency band up to twice the operating frequency.

BCM-RF-E modules must be installed in a RF-shielded chassis BCM-RFC/xx as provided by Bergoz Instrumentation.

Installation inside a vacuum chamber

Note: Only In-vacuum models are concerned by this chapter.

When a Turbo-ICT-VAC is installed inside a vacuum chamber, the cable going to the BCM-RF-E must be passed via an isolated coaxial vacuum feedthrough, i.e., with no contact to the enclosure by either the cable shield or the central conductor.

More information and latest manuals revisions can be found on our website

www.bergoz.com

If you have any questions, feel free to contact us by e-mail

info@bergoz.com

