

BCM-IHR-E

Beam Charge Monitor Integrate Hold Reset

Rev. 4.0



www.bergoz.com

bergoz[™]
INSTRUMENTATION

More than 40 years of experience recognized in the world of particle accelerators

Record of updates

Version	Date	Updates performed
2.1	02/2008	<p>p.6: Oscilloscope plot, trace 3 changed to "Output View". Oscilloscope plot, trace 1 changed to "Signal View".</p> <p>p.7: Oscilloscope plot, trace 3 changed to "Output View". Oscilloscope plot, trace 1 changed to "Signal View".</p> <p>p.8: Oscilloscope plot, trace 3 changed to "Output View". Oscilloscope plot, trace 1 changed to "Signal View".</p> <p>p.15: Trigger delay range specified: 350 ns ... 7.3 us. Ex-factory setting specified as 4 us.</p>
2.2	03/2008	p.3: Refers the user to Annex II for AC Mains Voltage change Instructions Annex II: Delta Elektronika U-Series Mains Voltage change Instructions
2.3	06/2011	p.12: Beam Charge to BCM Input Charge Ratio: 40:1 (instead of 50:1) for ICT with 20:1 turns ratio
3.0	01/2018	Review of the full manual. Obsoletes the previous versions
3.1	12/2019	Modification of the cover page and creation of the distributors' page
4.0	07/2024	Manual template update

DISTRIBUTORS

U.S.A.

GMW Associates

GMW Associates
www.gmw.com
sales@gmw.com

Japan

HR HAYASHI-REPIC

Hayashi-Repic Co., Ltd.
www.h-repic.co.jp
sales@h-repic.co.jp

India

GEEBEE
INTERNATIONAL

GEEBEE International
www.geebinternational.com
info@geebinternational.com

China

CONVe-YI 北京科维泰信

Beijing Conveyi Limited
www.conveyi.com
sales@conveyi.com

South Korea

SEYOUNG

Seyoung Co., Ltd
www.seyoungsys.com
apark@seyoungsys.com

SUMMARY

INITIAL INSPECTION 3

WARRANTY 3

ASSISTANCE 3

SERVICE PROCEDURE 3

RETURN PROCEDURE 4

SAFETY INSTRUCTIONS 4

BCM-IHR SET 5

 BCM-IHR version 5

 BCM-IHR-E front panel 5

 DB9 Remote control key 6

GENERAL DESCRIPTION 7

 System components 7

OPERATING PRINCIPLE 8

 Integrating Current Transformer 8

 Cable connection 9

 Signal processing 9

 Timing of the BCM-IHR 10

 Beam Charge Monitor Output 11

 On-line calibration 11

BCM-IHR SYSTEM CHECK 12

 Voltage Check 12

 Quick Check 12

 Setup 13

 Waveforms 14

 Explanation of the Timing View: 16

 The BCM-IHR system does not behave as described 17

 Testing all other BCM-IHR-E functions 17

SENSITIVITY OF THE BCM-IHR-E 18

 Full scales 18

 Most sensitive configuration 18

 Least sensitive configuration 18

REMOTE RANGE and CALIBRATION SWITCHING 19

SPECIFICATIONS 20

 Beam Charge Monitor 20

 Power supply and fuses 21

MAKING PRECISE MEASUREMENTS WITH THE BCM-IHR-E 22

SETTINGS 22

 Front-panel potentiometers 22

 On-board potentiometers 22

CONNECTOR PINS ALLOCATION 23

BCM CHASSIS 23

INITIAL INSPECTION

It is recommended that the shipment be inspected immediately upon delivery. If it is damaged in any way, contact Bergoz Instrumentation or your local distributor. The content of the shipment should be compared to the items listed on the invoice. Any discrepancy should be notified to Bergoz Instrumentation or its local distributor immediately. Unless promptly notified, Bergoz Instrumentation will not be responsible for such discrepancies.

WARRANTY

Bergoz Instrumentation warrants its beam current monitors to operate within specifications under normal use for a period of 12 months from the date of shipment. Spares, repairs and replacement parts are warranted for 90 days. In exercising this warranty, Bergoz Instrumentation will repair, or at its option, replace any product returned to Bergoz Instrumentation or its local distributor within the warranty period, provided that the warrantor's examination discloses that the product is defective due to workmanship or materials and that the defect has not been caused by misuse, disassembly, neglect, use of faulty part, accident or abnormal conditions, repair made by the customer, or operations. Damages caused by ionizing radiations are specifically excluded from the warranty. Bergoz Instrumentation and its local distributors shall not be responsible for any consequential, incidental or special damages.

ASSISTANCE

Assistance in installation, use or calibration of Bergoz Instrumentation beam current monitors is available from Bergoz Instrumentation, 01630 Saint Genis Pouilly, France. It is recommended to send a detailed description of the problem by email to info@bergoz.com.

SERVICE PROCEDURE

Products requiring maintenance should be returned to Bergoz Instrumentation or its local distributor: The purchaser/customer must ask for a RMA (Return Material Authorization) number to Bergoz Instrumentation or its local distributor before return of goods. Bergoz Instrumentation will repair or replace any product under warranty at no charge.

For products in need of repair after the warranty period, Bergoz Instrumentation will assess the technical issue and send a quote to the purchaser/customer. The purchaser/customer must provide a purchase order before repairs can be initiated. Bergoz Instrumentation can issue fixed price quotations for most repairs.

RETURN PROCEDURE

All products returned for repair should include a detailed description of the defect or failure as well as name, phone number and email of a contact person to allow further inquiry. Contact Bergoz Instrumentation or your local distributor to determine where to return the product. Returns must be notified by email prior to shipment.

The shipment of a product under warranty or out of warranty back to the factory is paid by the user/customer, including the customs fees. The return of this repaired product under warranty back to the customer is paid by Bergoz Instrumentation.

Return of product out of warranty should be made prepaid or will be invoiced. Bergoz Instrumentation will not accept freight-collect shipments. Shipments should be made via UPS, FedEx or DHL. Within Europe, the transportation services offered by the national Post Offices can be used. The delivery charges or customs clearance charges arising from the use of other carriers will be charged to the customer.

SAFETY INSTRUCTIONS

This instrument is operated from the mains power supply. For safe operation, it must be grounded by way of the grounding conductor in the power cord. Use only the fuse specified. Do not remove cover panels while the instrument is powered. Do not operate the instrument without the cover panels properly installed.

Chassis originally shipped to U.S. or Canada feature AC mains power entry modules where the Phase is fused and the Neutral unfused, as is the rule.

Chassis to other destinations but U.S. and Canada feature AC mains power entry modules where both Phase and Neutral are fused.

When a chassis with unfused Neutral shall be used outside the U.S. and Canada, fuse configuration must be modified so that both Phase and Neutral will be fused:

The Power entry module must be opened, the Phase fuse must be removed, the fuse holder must be flipped; its reverse side presents two slots where two new fuses must be inserted, one in each slot. The fuses rating must be same as the Phase fuse that was removed.

The Toroid sensor contains materials such as cobalt and iron. Those materials may become radioactive when exposed to high energy particle beams. Follow applicable radiation-safety procedures when the Toroid sensor must be handled.

BCM-IHR SET

BCM-IHR version

This manual applies to newer BCM-IHR-E Beam Charge Monitor, Integrate-Hold-Reset versions. These BCM-IHR sets usually consist of at least one BCM-IHR-E electronics module and one BCM-RFC/xx 3U x 19" chassis.

This User's manual does not describe older BCM versions, housed in an ABS plastic enclosure. Those are described in other manuals:

- *Beam Charge Monitor, Integrate-Hold-Reset User's Manual, version 1.x.x.*
- *Beam Charge Monitor, Continuous Averaging User's Manual, version 1.x.x*

These older versions consist of three modules in ABS plastic enclosures marked:

- *"C.A.C." for Charge Amplifier and Calibration*
- *"BSP-CA" or "BSP-IHR" for Bunch Signal Processor and*
- *a Delta Elektronika or Schroff power supply module*

These older configurations may include a Wideband Amplifier.

BCM-IHR-E front panel

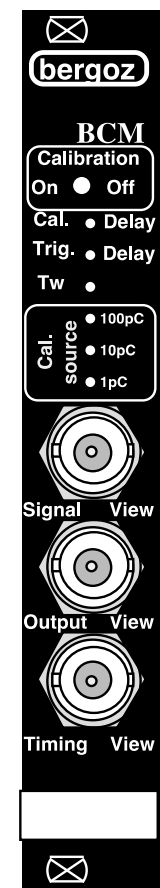

Front panel

WARNING: Jumper configuration & Potentiometer settings

The BCM-IHR-E is in the "Ex-factory" configuration. Jumper and timing adjustments (potentiometers) have been configured according to the order.

Do not change those settings until you are familiar with the Beam Charge Monitor.

DB9 Remote control key

A "DB9 Remote control key" is supplied with the Beam Charge Monitor. Its purpose is to control the BCM-IHR-E ranges when the accelerator control system is not connected. It is a small auxiliary printed circuit board attached to a DB9 connector. An 8-bit switch is mounted on the printed circuit board.

It must be plugged to the DB9 Remote control connector at the rear of the BCM chassis to allow measurement range switching and setup of calibration pulse characteristics.

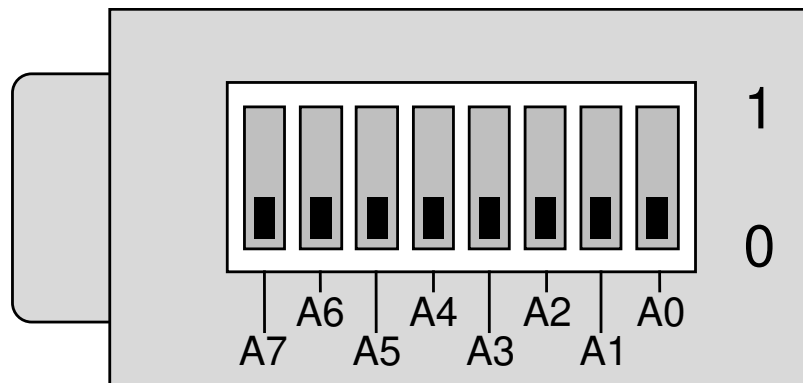

Switches A0...A6 are active. They correspond to Bits 0...6 of the remote control (See "Remote Range and Calibration Switching", this manual).

Position 1 corresponds to bit HIGH. Position 0 corresponds to bit LOW.

Switch A7 is not connected. The corresponding bit 7 controls "Calibration Enable". This function can be enabled by the BCM front panel switch.

GENERAL DESCRIPTION

BCM-IHR-E, Beam Charge Monitor Integrate-Hold-Reset version is designed to read the output signal of an ICT Integrating Current Transformer. BCM-IHR-E measures the charge of a single pulse or macropulse when it is triggered by an external trigger signal. It supports pulse/macropulse repetition rates up to 1 kHz.

System components

ICT Integrating Current Transformer is the sensor matching BCM-IHR-E. ICT is available in two styles:

- In-flange ICT to be bolted in-line with the vacuum chamber
- In-air ICT to be installed over the vacuum chamber

Both styles of ICT and their respective installations are described in "ICT Integrating Current Transformer User's Manual".

BCM-IHR-E processes the beam signal from ICT.

Electronics cards are housed in a 3U-high, 19"-wide RF-shielded chassis, which can hold:

- BCM-IHR-E, BCM-RF-E or BCM-CW-E modules, in any mix.
- Power Supply.

BCM-IHR-E output is a voltage up to +8V, proportional to the beam charge. The voltage level is held constant up to 400 μ s, then resets.

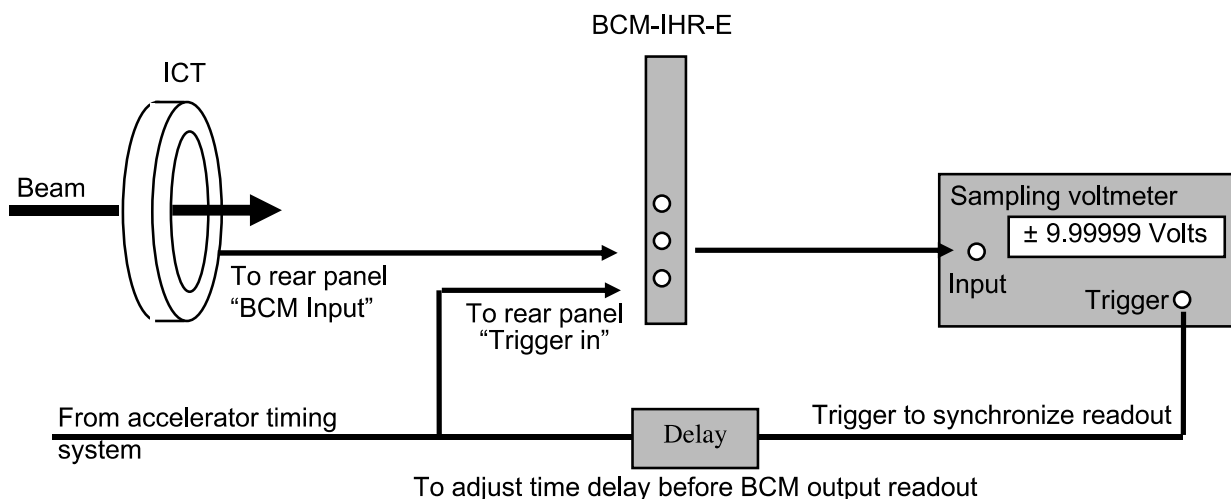

OPERATING PRINCIPLE

Integrating Current Transformer

ICT Integrating Current Transformer is a passive transformer designed to measure charges of very fast pulses with high accuracy. Beam pulses may have any length shorter than the ICT output signal.

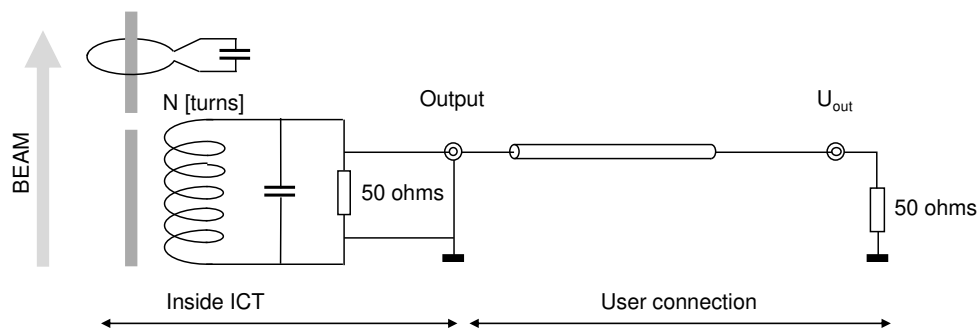

The ICT is a fast capacitively shorted transformer coupled to a slow readout transformer in a common magnetic circuit¹.

It delivers a pulse with typically 30 ns rise time irrespective of the beam pulse rise time. The ICT output pulse charge is in exact proportion to the beam pulse charge.

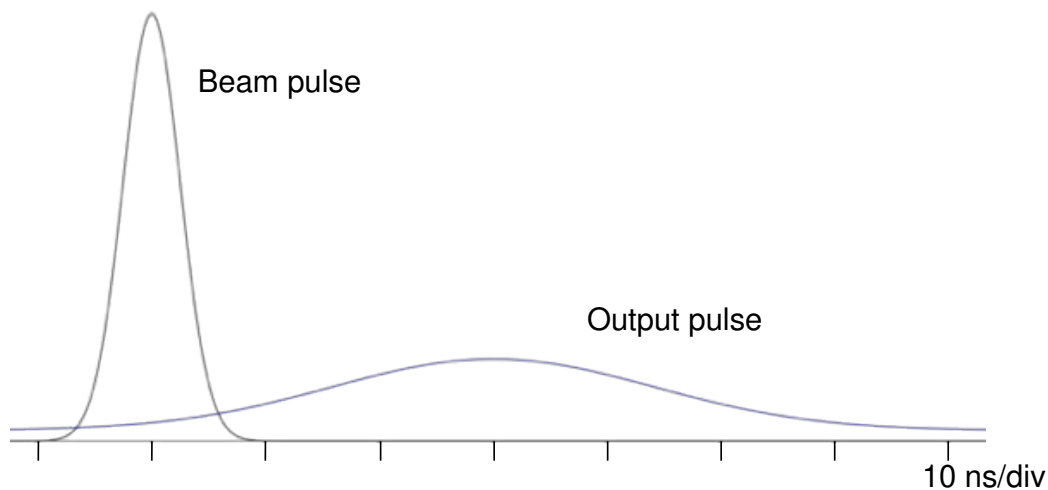

The sensitivity of the Integrating Current Transformer is also called transfer impedance. It depends on the ICT model. It is expressed in terms of the integral of the output pulse voltage as a function of the input pulse charge, therefore in Vs/C , or Ω .

¹ Measuring Bunch Intensity, Beam Loss and Bunch Lifetime in LEP, K.B.Unser, Proceedings of the 2nd European Particle Accelerator Conference, 1990, Vol.1, p.786

Cable connection

Most 50Ω coaxial cable types are appropriate to connect the ICT to its measuring instrument, for example an oscilloscope. However, the longer the cable and the lower the charge to be measured, the higher are demands on coaxial cable performance.

To measure charges below 500 pC, depending on the environmental background noise, consider using double-shielded cables or cables with a solid shield.

Depending on length and type, coaxial cables deform and attenuate pulsed signals. When the ICT signal is integrated, integration may be affected by such cable induced pulse attenuation and deformation. It is therefore recommended to use large diameter, low-loss cables for longer distances.

Signal processing

The BCM-IHR-E input signal is amplified by the Charge Amplifier. The amplified signal enters the Bunch Signal Processor, which integrates this signal every time the BCM-IHR-E is triggered by an external trigger. This gives the possibility to measure selected pulses only, not necessarily at a fixed repetition rate.

The signal processing is initiated by the rising edge of an external trigger pulse. A sequence timer creates three successive time windows: a trigger delay, a subtracting window and an adding window. The pulse to be integrated must fall either in the adding window, or the subtracting window. Pulses falling in the first window (trigger delay) are not integrated. At the start of the first integration window, the baseline is clamped to set the zero reference. The two integration windows are used to integrate the input signal in two independent integrators.

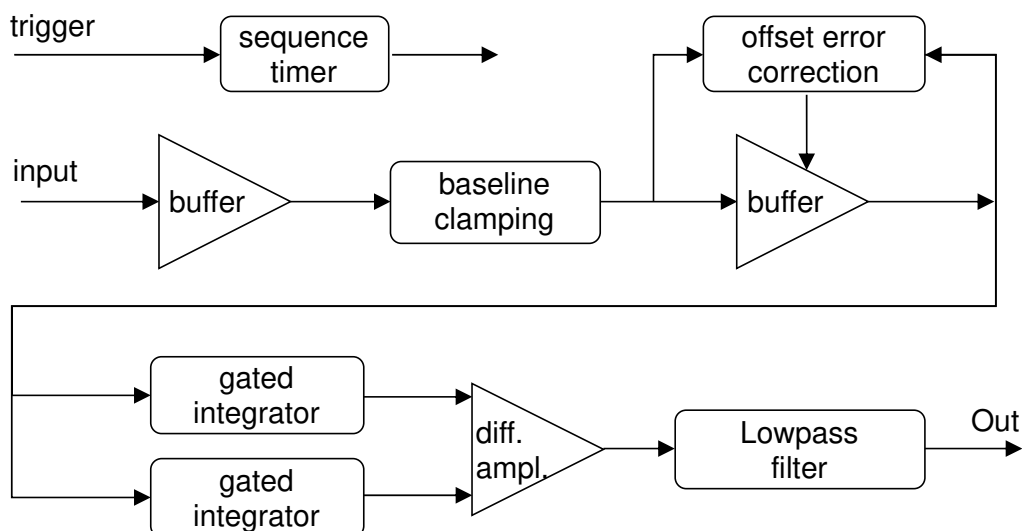

One integrator integrates the pulse signal. The other integrates the input noise and baseline offset. The pulse charge is obtained by summing the two integrators: the first with negative sign, the second with positive sign.

This particular combination of sampling window integrators gives a high degree of noise suppression. All signals which do not correlate in frequency and in time with the window timing are rejected. This applies to the amplifier noise and also to the general background. The balance of integrator gains is user-adjustable with the Window Balancing potentiometer.

Timing of the BCM-IHR

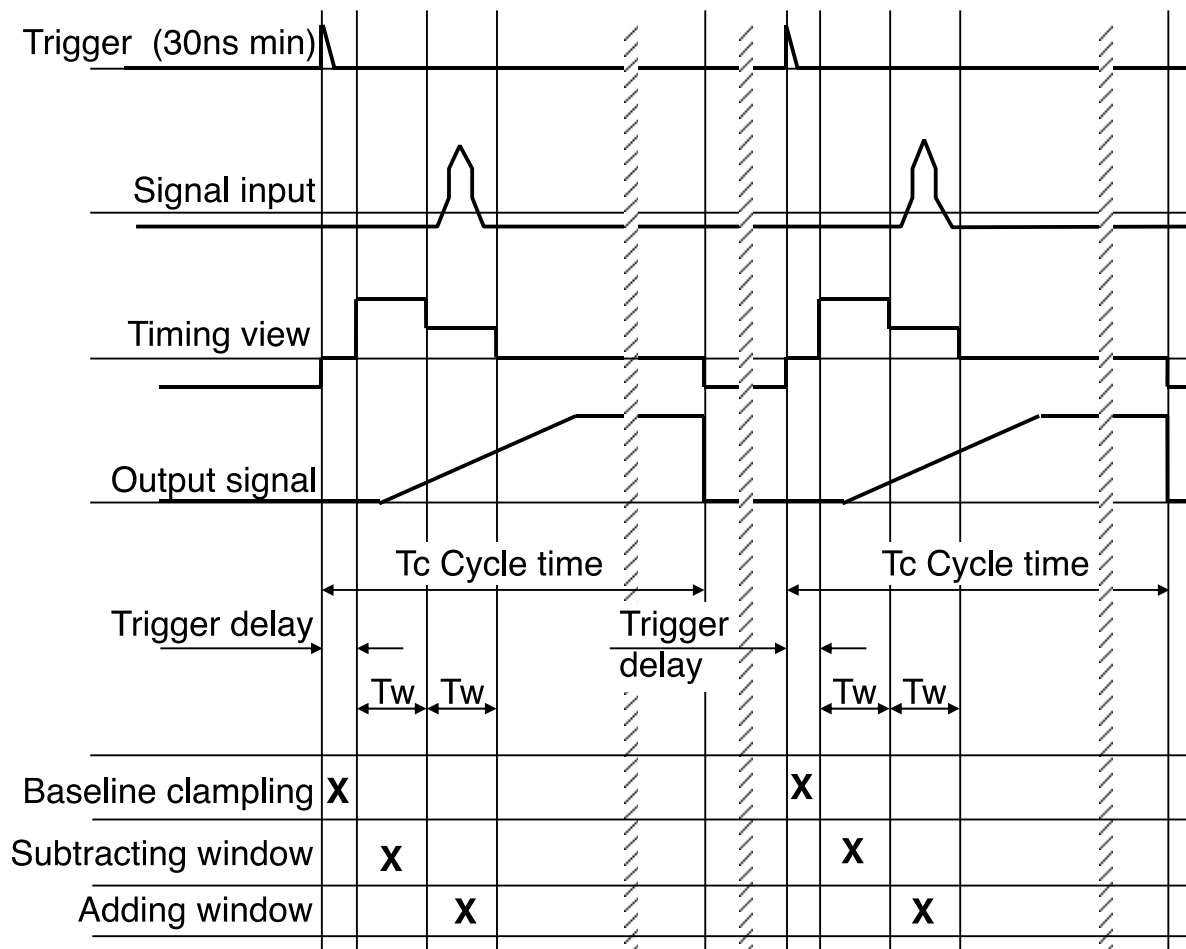

Trigger delay is adjustable from 350 ns minimum to 7.3 μ s maximum using front-panel potentiometer "Trig. Delay". In ex-factory conditions, it is set to 4 μ s.

The two integration windows are of equal width " T_w ". T_w is adjustable using front-panel potentiometer " T_w ". In ex-factory conditions, it is set to 4 μ s.

The Hold time or Cycle duration T_c can be adjusted by potentiometer "Cycle (Hold) Time". It is located on the BCM-IHR-E board. The cycle duration T_c must not be made shorter than the sum of the trigger delay and the two integration windows.

For Cycle (Hold) times surpassing the value that can be adjusted with the potentiometer, please contact Bergoz Instrumentation at info@bergoz.com.

Beam Charge Monitor Output

The output is a DC level up to +8V, proportional to the pulse charge. The output voltage is the difference between the value of the subtracting integrator and the adding integrator. It may have an offset which can be adjusted by the user with the on-board "Output Zero Offset" potentiometer. To eliminate this offset and make precision measurement, see chapter "Making precise measurements with the BCM-IHR-E", in this manual.

The output is available on the SMA connector located at the chassis rear panel. A front-panel BNC "Output View" is also available, for example to attach an oscilloscope.

Warning: Loading the front-panel "Output View" with too low impedance may change the rear panel "BCM Output".

The output voltage corresponds to the last triggered pulse. The signal settles to the correct value within $<20 \mu\text{s}$ after the end of the second window. It is held at that level until the end of the cycle, then it resets to zero. The cycle time T_c or "Hold time" can be adjusted using on-board potentiometer "Cycle (Hold) Time".

To locate on-board potentiometers, please refer to chapter "Settings", in this manual.

On-line calibration

On-line calibration of the BCM-IHR-E is possible at any time when there is no beam. Even when the no-beam time is short, on-line calibration may still be possible.

BCM-IHR-E is equipped with a precise calibration generator. The calibration generator is enabled when the front-panel switch "Calibration" is turned ON. The calibration generator can also be enabled by applying a high level to the "Calibration" pin on the DB9 connector. When the calibration generator is enabled, it sends two calibrated pulses, one positive, the other negative, a short time after it receives a trigger. The delay between the trigger and the first calibration pulse can be adjusted with the front-panel potentiometer "Cal. Delay". The calibrated pulse is applied to the BCM-IHR-E input charge amplifier and is intended as calibration for the BCM-IHR-E only, not the ICT. However, for correct calibration, the ICT and its cable must be connected to BCM input located on the BCM chassis rear panel.

The pulse charge splits in two parts. One part is lost in the cable and the ICT. The remaining part is amplified by the charge amplifier. "Cal. Delay" must be adjusted to make the calibrated pulse fall within either of the BCM-IHR-E integration windows.

The purpose of the pulse charge generator is not to provide accurate calibration. The calibration pulse generator provides pulses calibrated to ca. $\pm 2\%$.

Using the available controls, the calibration charge value can be set to either 1 pC, 10 pC, 100 pC or 1 nC and the calibration pulse polarity can be set to positive or negative. Controls are selected by TTL external levels applied to the DB9 connector at the rear of the BCM chassis.

Beware, this is charge as applied to the input of the Charge Amplifier. It is not beam pulse charge equivalent!

To obtain beam charge equivalents, use the table hereafter:

Calibration pulse in pC		1	10	100	1'000
Equivalent beam pulse, in pC					
With sensor:					
ICT-XXX-XXX-0.50	Exactly	100	1'000	10'000	100'000
ICT-XXX-XXX-1.25	Exactly	40	400	4'000	40'000
ICT-XXX-XXX-2.50	Exactly	20	200	2'000	20'000
ICT-XXX-XXX-5.00	Exactly	10	100	1'000	10'000
ICT-XXX-XXX-10.0	Exactly	5	50	500	5'000

BCM-IHR SYSTEM CHECK

Voltage Check

BCM chassis is equipped with Minmax AKF-15D15 power supply units² Their AC mains input range is 85Vac to 263 Vac, 50/60Hz.

If the mains voltage does not fall within those limits, contact Bergoz Instrumentation at info@bergoz.com.

Quick Check

You can check immediately that your BCM system is working. This is what you need:

- Beam Charge Monitor Integrate-Hold-Reset: at least one BCM-IHR-E electronics module and one BCM-RFC/xx chassis
- DB9 Remote control key
- ICT Integrating Current Transformer
- 4-channel oscilloscope with 100 MHz bandwidth
- Pulse generator capable of creating a trigger pulse (≥ 30 ns, ≥ 2.4 V in 50ohm, 1 kHz)

You will also need short (1-2 m) BNC cables and SMA-BNC adapters.

² https://www.minmax.com.tw/en/download/files/1351/AKF-15_Datasheet.pdf

Setup

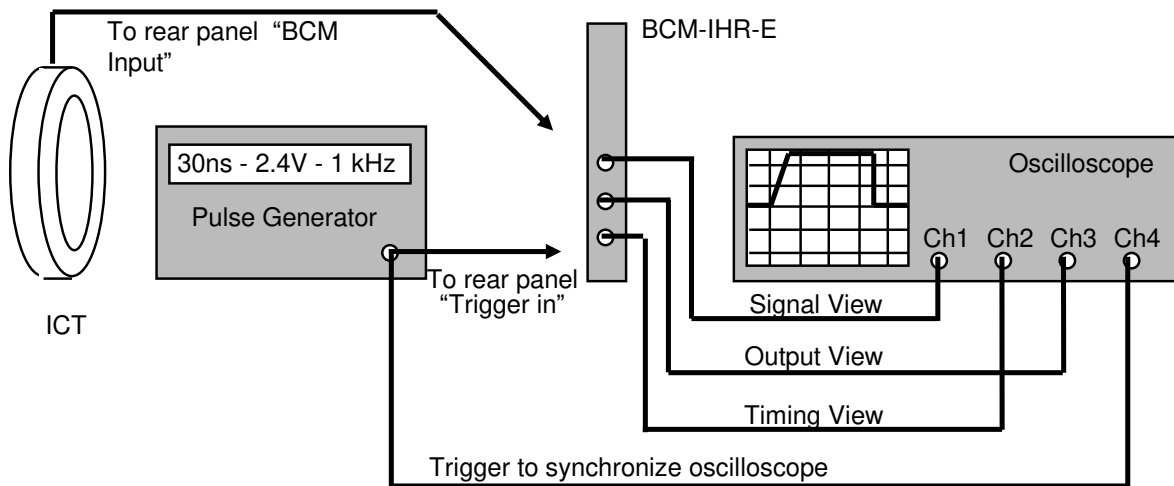

Connect as shown on picture:

ICT output to "BCM Input" on BCM chassis rear panel.
 Insert DB9 "Remote Control" key in chassis rear panel DB9 connector.
 All Remote Control switches should be OFF, i.e. on "0" (zero).

Reminder: Make sure that the AC mains voltage corresponds to BCM mains voltage.
 Connect BCM chassis AC input to the mains.

Apply a pulse (>30ns, >2.4V, 1 kHz) to "Trigger in" on rear panel (50 ohm terminated).
 Apply same pulse to oscilloscope input channel.
 Set this oscilloscope input channel to high-impedance and set up the oscilloscope to trigger on this channel.

Set front-panel "Calibration" toggle switch to ON.
 Look at the signals with the oscilloscope, all channel inputs must be high-impedance.

Waveforms

Reminder: The front panel "Calibration" toggle switch should be ON.

The signals should look like this:

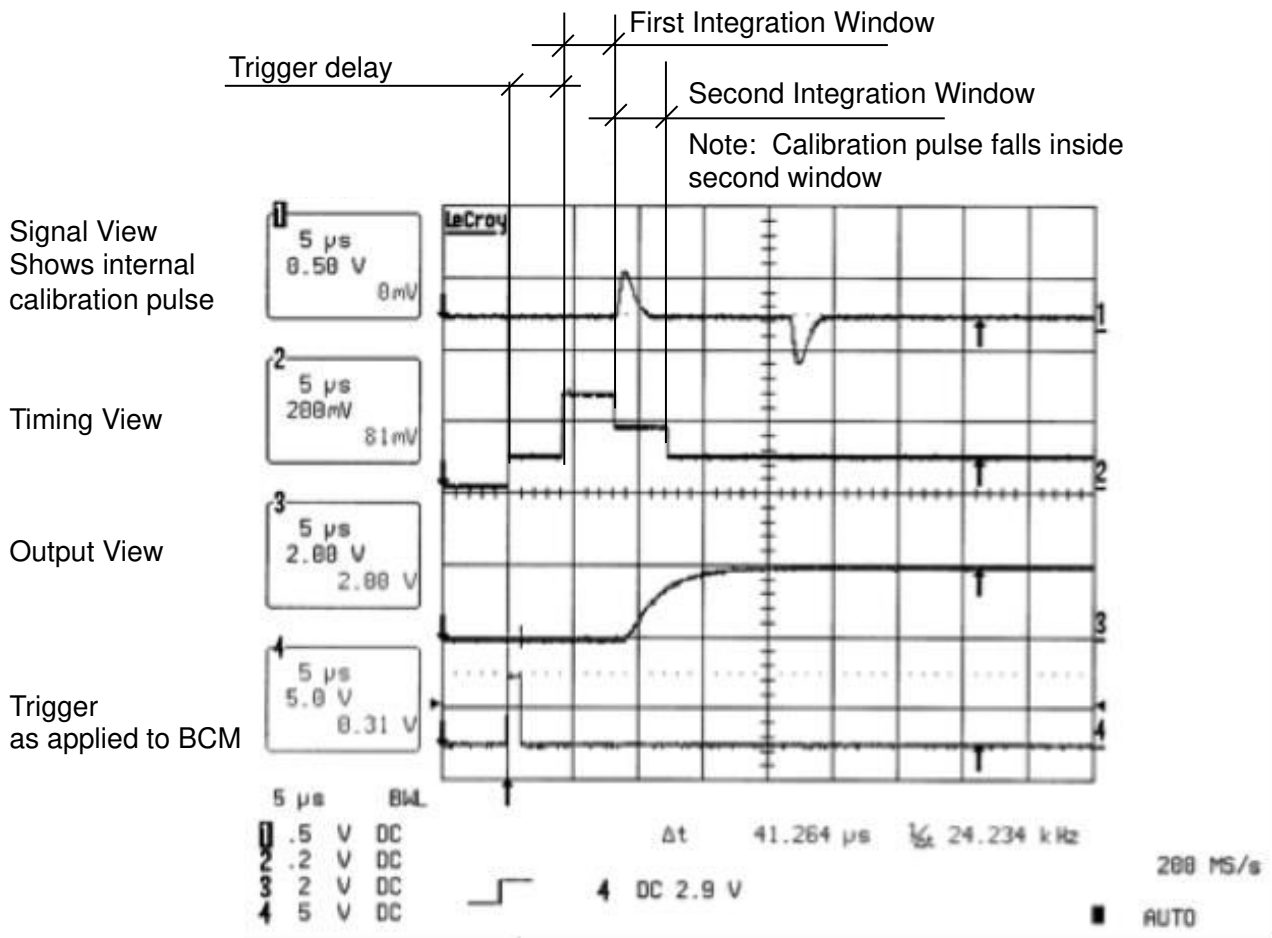

Testing the BCM-IHR-E:

Turn the BCM-IHR-E "Cal. Delay" 20-turn front panel potentiometer: It changes the delay between the trigger and the calibration pulse. The calibration pulse can be moved from the second integration window (the "adding" window) into the first integration window (the "subtracting" window).

When the calibration pulse fits entirely into the first integration window (subtracting window), oscilloscope traces should look like this:

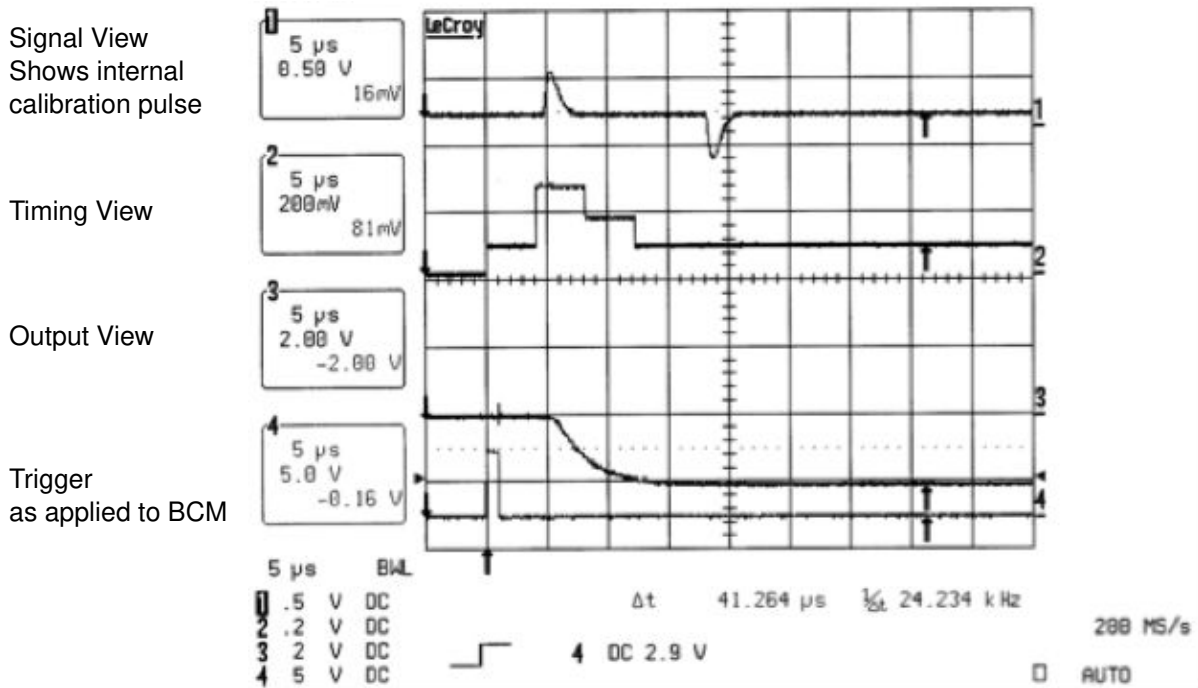

Adjust the oscilloscope time base to a slower sweep: 50 μ s / div. Oscilloscope traces should look like this:

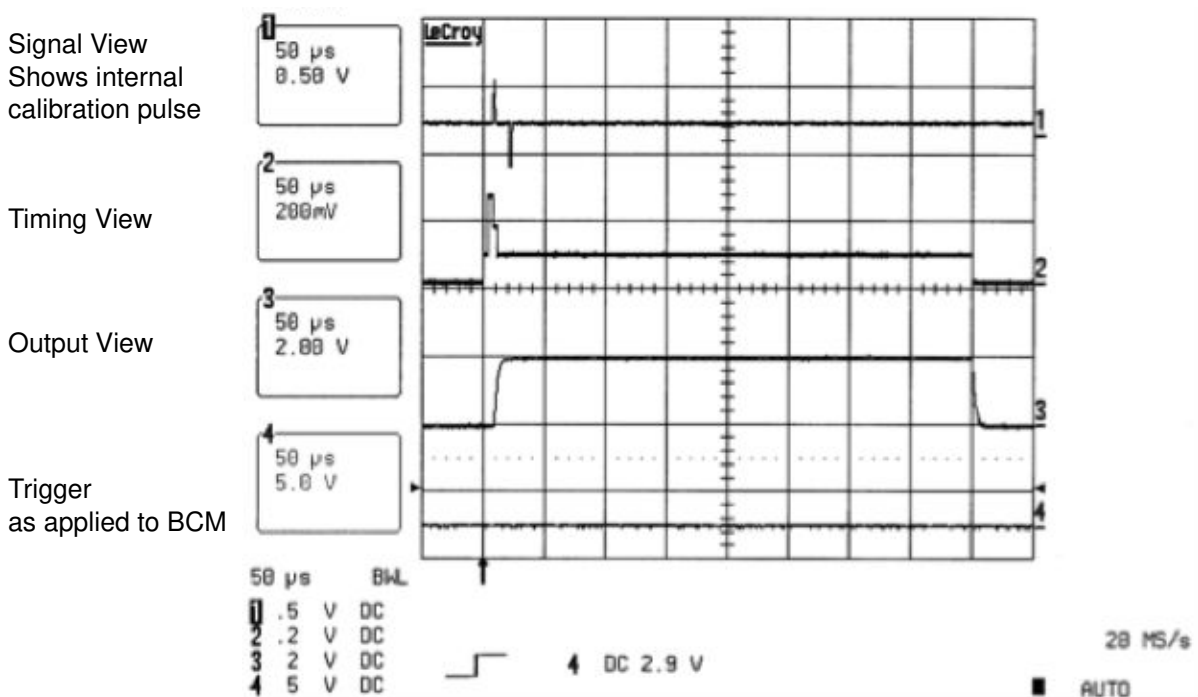

The complete BCM-IHR-E cycle is visible on the oscilloscope including the BCM output reset to zero after 400 μ s.

Explanation of the Timing View:

Timing View is a signal helping the user during BCM-IHR-E setup:

- a) adjust beam pulse position inside integration windows
 - b) adjust timing of readout ADC or sampling voltmeter with respect to BCM output signal.
- The Timing View voltage levels are arbitrary.

- Signal lowest level, at the beginning of the trace: Beam Charge Monitor is ready to receive a Trigger.
- First step, rising edge: BCM-IHR-E has received a trigger signal. The trigger delay is elapsing (4 μ s in ex-factory conditions)
- Second step, rising edge: Trigger delay has elapsed. The first integration window starts. In ex-factory conditions it lasts 4 μ s. During this window, the signal is summed in the output with a negative sign. It is the "subtracting" window.
- Third step, falling edge: The first or "subtracting" integration window has finished. The second integration window starts. In ex-factory conditions, this window has equal duration to the first integration window duration. During this window, the input signal is summed with a positive sign. It is the "adding" window.
- Fourth step, falling edge: The second or "adding" integration window has finished. The hold time starts. During the hold time, the BCM-IHR-E output value is held at a constant level. In ex-factory conditions the hold time terminates 400 μ s after the trigger.
- Final step, falling edge: The hold time has finished. The BCM-IHR-E output is reset to zero. The Beam Charge Monitor is ready to receive another trigger.

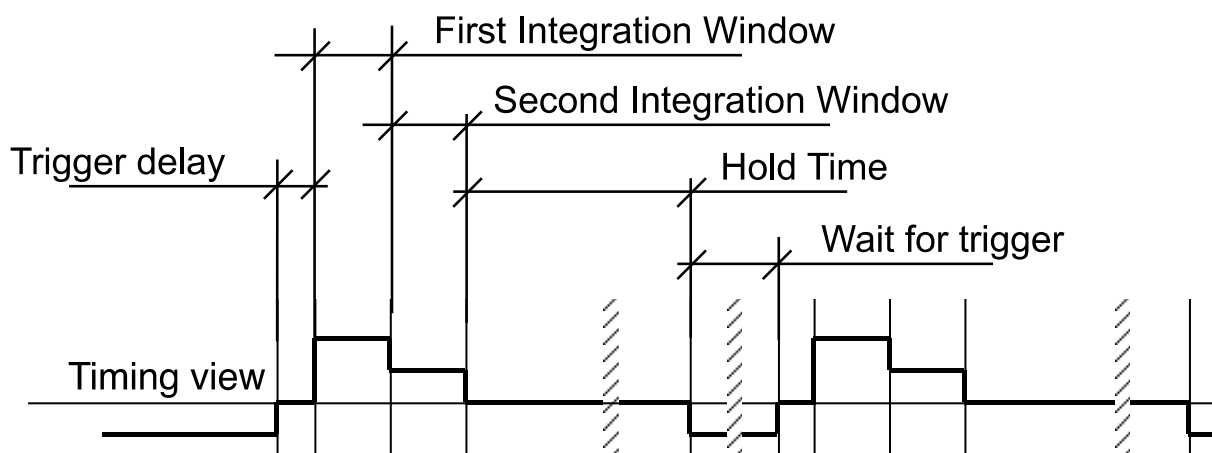

The BCM-IHR system does not behave as described

If your BCM-IHR-E is in ex-factory conditions, it should behave as described above. If it does not, check the switch settings on the "Remote Control" key: All switches should be in the OFF, i.e., "0" (zero) position.

If your BCM-IHR-E is not anymore in ex-factory conditions, the front panel potentiometers settings may have been changed.

To re-establish the ex-factory settings:

- Turn potentiometer "Trig. Delay" located on BCM-IHR-E front-panel until the trigger delay equals 4 μ s.
- Turn potentiometer "Tw" located on BCM-IHR-E front-panel until the integration window width equals 4 μ s.
- Turn potentiometer "Cal. Delay" on BCM-IHR-E front panel until the calibration pulse fits into an integrating window.

If those adjustments cannot be carried out, the instrument's time constants may have changed after delivery of the instrument. Either restore original values according to the schematics or contact Bergoz Instrumentation for recalibration at info@bergoz.com.

Testing all other BCM-IHR-E functions

You can test all gain ranges, inverse the signal polarity, change the value of the calibration pulse and its polarity:

Toggle the switches of the DB9 Remote control key. Place the switches A0 to A6 as explained in the section "Remote Range and Calibration Switching". Switch position 1 corresponds to bit HIGH. Position 0 to bit LOW.

Note that Switch A7 is not connected. The "Calibration Enable" control can be activated with the BCM-IHR-E front panel toggle switch.

SENSITIVITY OF THE BCM-IHR-E

Full scales

Gain	Bits (Gain setting) 2-1-0	Full scale with ICT-...- 0.50	Full scale with ICT-...- 1.25	Full scale with ICT-...- 2.50	Full scale with ICT-...- 5.00	Full scale with ICT-...- 10.0
6 dB	H-H-H	400 nC	160 nC	80 nC	40 nC	20 nC
12 dB	H-H-L	200 nC	80 nC	40 nC	20 nC	10 nC
18 dB	H-L-H	100 nC	40 nC	20 nC	10 nC	5 nC
20 dB	L-H-H	80 nC	32 nC	16 nC	8 nC	4 nC
26 dB	L-H-L or H-L-L	40 nC	16 nC	8 nC	4 nC	2 nC
32 dB	L-L-H	20 nC	8 nC	4 nC	2 nC	1 nC
40 dB	L-L-L	8 nC	3.2 nC	1.6 nC	0.8 nC	0.4 nC

Bits: L = low, H = high

Most sensitive configuration

The most sensitive configuration is obtained when using the most sensitive ICT and setting the highest BCM-IHR-E gain:

- two core ICT with 5:1 turns ratio (= 10 Vs/C sensitivity),
- BCM-IHR-E set to maximum gain (+20 dB on first stage and +20 dB on second stage)

The achievable performance is:

- Full scale is ± 400 pC for ± 8 V output
- Sensitivity is ~ 20 mV per pC of beam charge
- Noise is < 20 mV rms, i.e < 1 pCrms

Least sensitive configuration

The least sensitive configuration (without external signal attenuators) is obtained when using the least sensitive ICT and setting the lowest BCM-IHR-E gain:

- single core ICT with 50:1 turns ratio (= 0.5 Vs/C sensitivity),
- BCM-IHR-E set to minimum gain (+0 dB on first stage and +6 dB on second stage)

The achievable performance is:

- Full scale is ± 400 nC for ± 8 Volts output
- Sensitivity is ~ 20 mV per nC of beam charge
- Noise is < 0.2 mV rms, i.e. < 10 pC rms

REMOTE RANGE and CALIBRATION SWITCHING

All BCM-IHR-E functions can be controlled via a DB9 connector located on the back of the BCM chassis by applying TTL levels to the available 8 bits. An 8-bit DIP switch, attached to a DB9 male connector, is provided for user convenience, to simulate the presence of the control system. The BCM-IHR-E gain level, signal polarity, calibration pulse charge and calibration pulse polarity can be controlled.

Function				Bit#7	Bit#6	Bit#5	Bit#4	Bit#3	Bit#2	Bit#1	Bit#0
DB9 connector pin# (ground on pin#9)				5	1	6	2	7	3	8	4
Gain	Total	2 nd stage	1 st stage						H	H	H
	+6 dB	+6 dB	+0 dB						H	H	L
	+12 dB	+6 dB	+6 dB						H	L	H
	+18 dB	+6 dB	+12 dB						L	H	H
	+20 dB	+20 dB	+0 dB						L	H	L
	+26 dB	+20 dB	+6 dB						L	H	L
	+26 dB	+6 dB	+20 dB						H	L	L
	+32 dB	+20 dB	+12 dB						L	L	H
	+40 dB	+20 dB	+20 dB						L	L	L
Output Signal	Polarity		Non invert Invert					H L			
	Polarity		Positive Negative				H L				
Calibration	Charge selection		1 nC 100 pC 10 pV 1 pC		H H L L	H L H L					
	Enable/Disable		Enable* Disable	H L							
	*Calibration Enable and "Calibration" front-panel switch ON are OR'ed. Therefore, BCM will be in calibration mode whenever either Calibration Enable of "Calibration" switch is ON.										
Bits: L = low, H= high											

Note: The default state, i.e. the state when no external control signal is applied, is printed in **BOLD**.

SPECIFICATIONS

Beam Charge Monitor

Input charge	4 nC max
Input rise time	< 1ns in 50Ω termination
Gain steps	8 steps from 6 dB to 40 dB
Gain, fine adjustment	± 1 dB
Output	bipolar, up to ± 8 V, for high-impedance readout Output load 10 mA max.
Output settling time	< 30 μs after the trigger
Output signal hold time	up to 600 μs after the trigger (adjustable)
Front-panel connectors (BNC)	Signal View, for high-impedance read-out Output View, for high-impedance read-out Timing View, for high-impedance read-out
Rear module connector	DIN 41612-M / 24+8 male, with 1.0/2.4 coaxial inserts
Back-panel connectors (SMA)	BCM Input, 50-ohm coaxial cable from ICT BCM Output, for high-impedance readout Trigger Input, 50-ohm terminated
Back-panel DB9 female:	8 TTL controls for range control, calibration control and calibration enable
Front-panel switch	Calibration on/off
Front-panel potentiometers	Calibration delay (to fit calibration pulse in integrating window) Trigger delay (To adjust time from trigger to beam pulse) Window width "T _w " (To adjust integration window time)
Recessed front-panel potentiometers	Calibration Source (To fine-trim the calibration generator)
On-board potentiometers	Fine Level: gain adjust ±1dB Window Balancing Cycle (Hold) time Output Zero Offset
Calibration pulse absolute accuracy	±2%
Power consumption (module)	+15V, 110mA -15V, 85mA
Card size	3U x 4F, i.e. Eurosize 100 x 160 mm, 20mm wide
Chassis size	3U x 19"

Power supply and fuses

The mains voltage is factory set according to the label on the power supply module front panel. Please remove or correct this label when you change the mains voltage selection.

Type	AKF-15D15, $\pm 15V$ dual output
Manufacturer	MinMax, Tainan City 702, Taiwan
Output voltage	$\pm 15V$, ± 500 mA
Mains voltage	jumper selected: 110, 220 Vac, 50-60 Hz tested at 90 Vac/50 Hz for 100 Vac Japanese mains voltage
Mains voltage selector	located under the power supply block
Card size	3U x 10F, i.e. Eurosize 100 x 160 mm, 50mm width
Back-panel connector	Power supply mains are wired to a IEC connector via an EMI/RFI filter and fuse.

MAKING PRECISE MEASUREMENTS WITH THE BCM-IHR-E

To read the BCM-IHR-E output signal it is recommended to use high resolution digitizers, ADC cards or sampling voltmeters.

The voltage reading must be started (triggered) when the BCM-IHR-E output pulse is stable, i.e. $\geq 20\mu\text{s}$ after the BCM-IHR-E trigger pulse.

For precise measurements, the BCM-IHR-E output voltage should be sampled and averaged over 200 to 300 μs .

For improved accuracy, the BCM-IHR readout system should execute two measurement cycles:

- First measurement is with beam pulse.
- Second measurement is without beam pulse, to measure the zero offset.

The offset is deducted from the first measurement to obtain a more accurate value.

This technique has two advantages:

- a) The zero offset, which depends on the balancing between the adding and the subtracting integrators, is compensated. Any drift, e.g., due to temperature or ageing is eliminated.
- b) The mains frequency noise can be eliminated.

For 60 Hz mains, the noise can be rejected very effectively by making the two measurements at a time interval equal to $N \times 16.66\text{ms}$, where N is an integer 1, 2, 3....

For 50 Hz mains, the time interval must be equal to $N \times 20\text{ms}$.

SETTINGS

Front-panel potentiometers

Window width "T_w"

Determines the width "T_w" of the integration windows.

Allows an adjustment from $<0.1\mu\text{s}$ up to $>7\mu\text{s}$.

Factory set as shown on the "Factory Settings" label affixed to the BCM module.

Trig. delay

Adjusts the delay from the trigger until the beginning of the first integration window.

Factory set as shown on the "Factory Settings" label affixed to the BCM module.

Cal. Source

Allows fine trimming of the calibration generator. Please note: Ex-factory calibration will be lost when Cal. Source potentiometer settings are modified.

On-board potentiometers

Access to on-board potentiometers is normally not required. For any assistance, please contact info@bergoz.com.

CONNECTOR PINS ALLOCATION

Mating connector: use any DB9 female connector. Locking with UNC4-40 screws.

Gain selection

Bit 0	4
Bit 1	8
Bit 2	3
Signal polarity	7
Calibration polarity	2
Calibration charge selection		
Bit 0	6
Bit 1	1
Calibration Enable	5
Ground	9

BCM CHASSIS

The BCM-RFC/xx chassis is based on a 19" Schroff rackable RF-shielded chassis.
Bin dimensions: 3U x 84F

Schroff reference: Europac Lab HF/RF #20845-283

The BCM-RFC/xx can be wired with up to 12 BCM-E stations, xx being the number of wired stations (one BCM-E module per station).

Unwired stations are masked with RF-shielded blank panels.

BCM-RFC/xx outer dimensions:

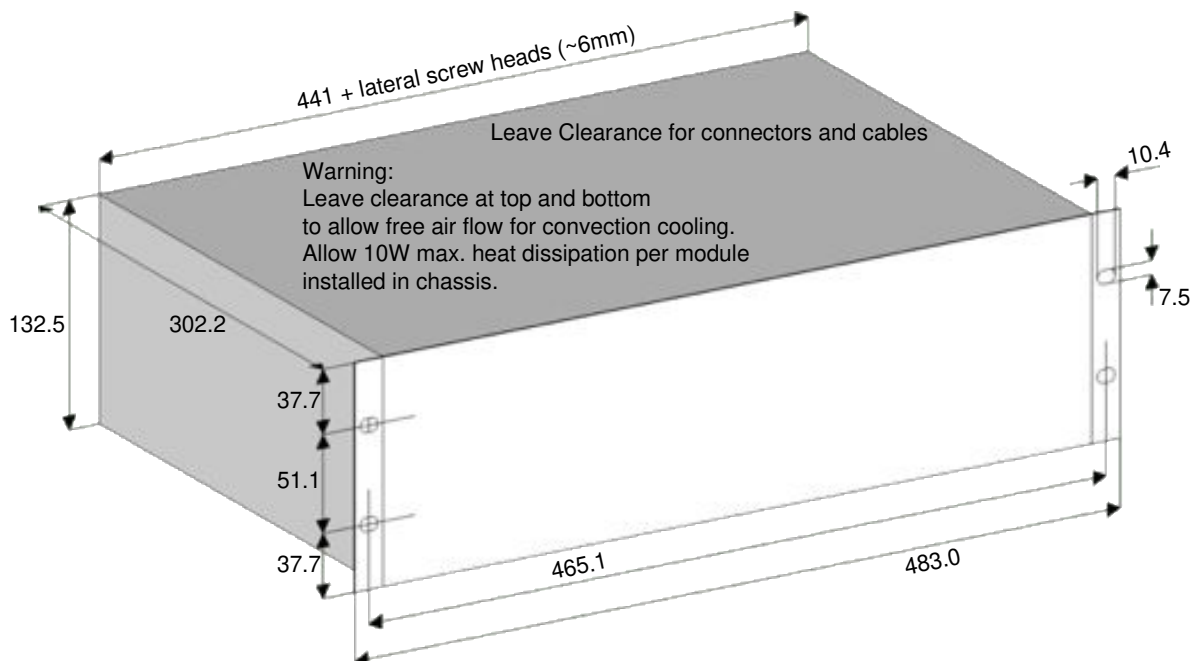

More information and latest manuals revisions can be found on our website

www.bergoz.com

If you have any questions, feel free to contact us by e-mail

info@bergoz.com

